



Real Estate Report

Technical Specifications for Batch XML Filers



Note: These instructions are designed to help filers understand how to technically prepare and file the Real Estate Report using FinCEN's BSA E-Filing System. They do not alter or replace any requirements established by statute or regulation. FinCEN may update these instructions to provide clarification or reflect changes. For additional and latest information, consult www.fincen.gov/rre.

Contents

1.	Introduction	3
2.	RER XML Schema Overview	5
3.	XML Batch File Organization	7
3.1.	XML declaration (prolog)	7
3.2.	EfilingBatchXML (Batch)	7
3.3.	Activity (RER).....	9
3.4.	ActivityAssociation (Type of Filing)	12
3.5.	Party (General).....	13
3.5.1.	Party: Reporting Person.....	14
3.5.2.	Party: Transferee	17
3.5.2.1.	If Transferee is an Entity	17
3.5.2.2.	If Transferee is a Trust	23
3.5.2.3.	Party: Person Associated with the Transferee	26
3.5.2.3.1.	If Associated Person is a Beneficial Owner and/or Signing Individual	26
3.5.2.3.1.1.	Party: Person Associated with Signing Individual (Item 44)	35
3.5.2.3.2.	If Associated Person is a Trustee Legal Entity	36
3.5.3.	Party: Transferor.....	42
3.5.3.1.	If Transferor is an Individual or an Entity	42
3.5.3.2.	If Transferor is a Trust	48
3.5.3.2.1.	Party: Trustee Association with the Transferor Trust (individual or Entity)	51
3.5.4.	Administrative Data	57
3.5.4.1.	Party: Transmitter	57
3.5.4.2.	Party: Transmitter Contact.....	61
3.6.	AssetsAttribute (Property Address and Legal Description)	62
3.7.	ValueTransferActivity (Payment Information).....	64
3.7.1.	ValueTransferActivityDetail (Payment(s) made by or on behalf of Transferee(s))	66
3.7.1.1.	Assets (Payment Method)	69
3.7.1.2.	Party	70
3.7.1.2.1.	Party: Financial Institution (FI) where account held	70
3.7.1.2.2.	Party: Transferee associated with the Payment	72
3.7.1.2.3.	Party: Payor associated with the Payment	73
4.	RER XML Batch Acknowledgement	75
4.1.	XML File Structure.....	75
4.2.	XML declaration (prolog)	76
4.3.	EfilingBatchXML.....	76
4.4.	EfilingSubmissionXML	77
4.5.	EfilingActivityXML.....	78
4.6.	EfilingActivityErrorXML.....	79
5.	Attachment A – Error Descriptions	81
6.	Revision History	110

PURPOSE OF THIS GUIDE

This guide provides instructions for formatting the RER batch XML in accordance with the published RER schema. It is intended to clarify required structure, elements, and attributes specific to the schema. This guide does not serve as a tutorial on XML itself. Users are expected to have a working knowledge of XML concepts, syntax, and tools in order to successfully apply the guidance provided here. To access the RER batch schema, click [here](#).

1. Introduction

The Real Estate Report (RER) is a form issued by FinCEN for the purpose of reporting information on transfers of certain residential real estate that are a high risk for illicit finance. FinCEN supports the following RER electronic filing methods via the BSA E-Filing System:

- Single Discrete RER either via PDF form or online (web) form:
This method of filing is best suited for *lower* volume filers. Filers log in to BSA E-Filing to submit using this filing method.
- Multiple (i.e., *batch*) RERs in XML format:
This method of filing is best suited for *higher* volume filers who acquire (or create) software that facilitates the creation of XML files. Filers may submit a batch file manually via the BSA E-Filing website or automate the submission process via Secure File Transfer Protocol (SFTP). While FinCEN provides the ability to submit the RER data as a batch, the process of establishing a method/process to create the XML batch file is the responsibility of the filer.

IMPORTANT ADVISORY

Reporting persons are not required to report transactions that meet the definition of a "reportable transfer" and that close prior to March 1, 2026.

For the latest news and guidance related to the Residential Real Estate Rule, please visit www.fincen.gov/rre.

This user guide focuses on how to format the RER in a batch XML to submit either manually through the BSA E-Filing System website (<http://bsaefiling.fincen.gov>), or through [SFTP automation](#). All of the above methods of RER filing are via electronic submission using FinCEN’s BSA E-Filing System, which requires the submitter to obtain a [BSA E-Filing account](#).

IMPORTANT: Prior to submitting in the production BSA E-Filing System, filers should thoroughly test their batch filing process in the BSA E-Filing *sandbox* environment. To access the sandbox, filers must create a separate TEST account at [bsaefiling-sandbox.fincen.gov](#) > Enroll.

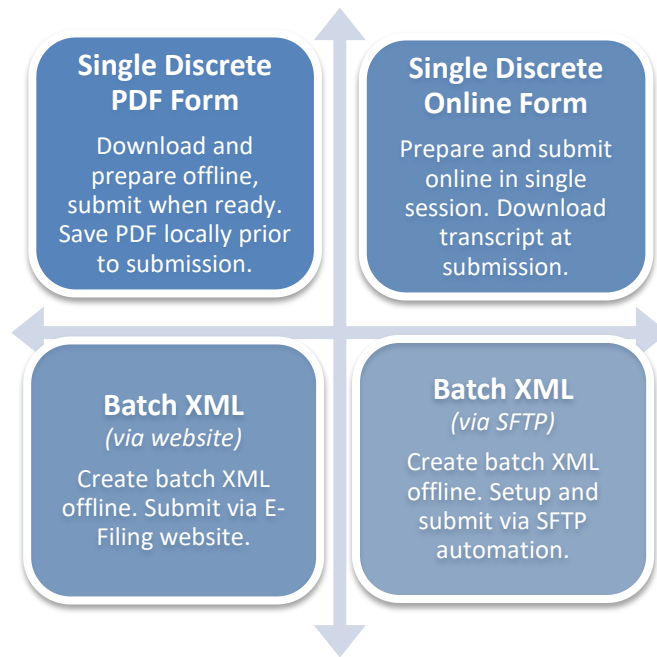

2. RER XML Schema Overview

Before you begin submitting RERs to FinCEN's BSA E-Filing System via XML batch, you must first review the RER batch schema to assist you with constructing and testing your XML batch file. This document helps guide the schema review process by clarifying required structure, elements, and attributes specific to the RER batch schema, such as which elements must be recorded, what the appropriate values are for each element, and what sequence the elements should be in. Please take note of the following as you review this guide:

- Simple elements have a value associated with them, while complex elements do not have a value associated with them; instead, they are containers for one or more additional elements (simple and/or complex);
- Each complex element (with the exception of the EFilingBatchXML element) must include the attribute "SeqNum" (i.e., Sequence Number) with a unique (i.e., the value cannot repeat in the batch) numeric value no greater than 19-digits;
- Element names must include the prefix "fc2" in both the opening tag and closing tag;
- Element names must match the case and spelling defined in the corresponding XML schema;
- Elements must have a matching closing tag (which includes a self-closing tag if no value is recorded for the element);
- Elements must be in the correct sequence (i.e., simple elements should be alphabetical order);
- Element names and values must NOT include leading or trailing spaces;
- Elements must be recorded once if minOccurs is not specified (or if minOccurs equals "1" in the XML schema);
- Elements may be omitted if minOccurs is equal to "0" and FinCEN guidance supports value omission (i.e., the name suffix element is minOccurs="0" and, therefore, if an individual does not have a suffix name, the element can be omitted rather than recording the element with no value);
- Elements must not be recorded in an occurrence greater than the specified maxOccurs limit (if no maxOccurs value is specific, then the maximum occurrence is "1");
- Element values must not exceed the maximum specified character limit; and
- Element values must not include non-printable characters, such as carriage returns, line feeds, and tabs.

Please also review the table below, which provides an overview of the XML Batch File Organization structure in the next section.

Column Name	Description
Element	<p>This column corresponds with the element name in the RER XML schema. The elements must be in the order in which they are recorded in this guide.</p> <p>Elements that contain a self-closing tag (e.g., <fc2:ActivityPartyTypeCode/>) are classified as simple elements (i.e., an element does not contain sub-elements). These elements are sometimes referred to as “child” elements.</p> <p>Elements that do not contain a self-closing tag (e.g., <fc2:Activity>) are classified as complex elements (i.e., elements that contain additional sub-elements). These elements are sometimes referred to as “parent” elements.</p> <p>As noted previously, all complex elements (with the exception of the root element) must contain the <i>SeqNum</i> attribute.</p>
Element restrictions	This column specifies the conditions for when and when not to record the element.
Value restrictions	This column specifies what value restrictions exist for this element, such as how many characters can be recorded, what format the value must be in, etc.
Item #	<p>This column connects the element to the corresponding item/field in the RER form.</p> <p>NOTE: If you see “XML” in this column for a specific element, this means it does not correspond directly to an item/field in the RER form, but the element is needed from an XML perspective.</p>

3. XML Batch File Organization

3.1. XML declaration (prolog)

The XML declaration (i.e., prolog) specifies the XML version and character encoding used in the file. The prolog must appear on the first line of the file.

```
<?xml version="1.0" encoding="UTF-8"?>
```

3.2. EFilingBatchXML (Batch)

The EFilingBatchXML element is the root element and serves as the container for all RERs recorded in the batch XML. The EFilingBatchXML element must be the first element recorded in the batch XML.

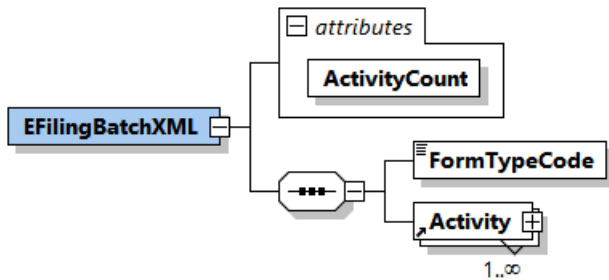

Element	Element Restrictions	Value Restrictions	Item #
<?xml version="1.0" encoding="UTF-8"?>	Prolog. Must be recorded once at the beginning of the RER batch XML.		
<fc2:EFilingBatchXML ActivityCount="#" xmlns:fc2= www.fincen.gov/base xmlns:xsi= http://www.w3.org/2001/XMLSchema-instance xsi:schemaLocation=www.fincen.gov/base " https://bsaefiling.fincen.gov/resources/EFL_RERXBatchSchema.xsd ">	Root. Must be recorded once in the RER batch XML. This element is the container for all RERs in the batch XML. It includes the following attributes: <ul style="list-style-type: none"> ActivityCount. The total count of all RERs in the batch XML. xmlns:fc2=www.fincen.gov/base xmlns:xsi=http://www.w3.org/2001/XMLSchema-instance xsi:schemaLocation=www.fincen.gov/base "https://bsaefiling.fincen.gov/resources/EFL_RERXBatchSchema.xsd" 		
<fc2:FormTypeCode/>	This element must be recorded.	Value must be "RERX".	XML

Element	Element Restrictions	Value Restrictions	Item #
<code><fc2:Activity SeqNum="#">...</fc2:Activity></code>	This element must be recorded at least once per batch XML. This element is the container for each RER (one Activity element per RER in the batch XML). For details about this element, see Activity		
<code></fc2:EfilingBatchXML></code>	Closing tag for the RER batch.		

3.3. Activity (RER)

Hierarchy: [EFilingBatchXML](#) / **Activity**

The Activity element is the container for all information regarding the RER. Each RER in the batch must begin with the Activity element.

NOTE: While there is no limit to the number of Activity elements (i.e., RERs) that may be recorded in a single batch XML file, the total size of the batch file should not exceed 60MB to ensure optimal processing performance.

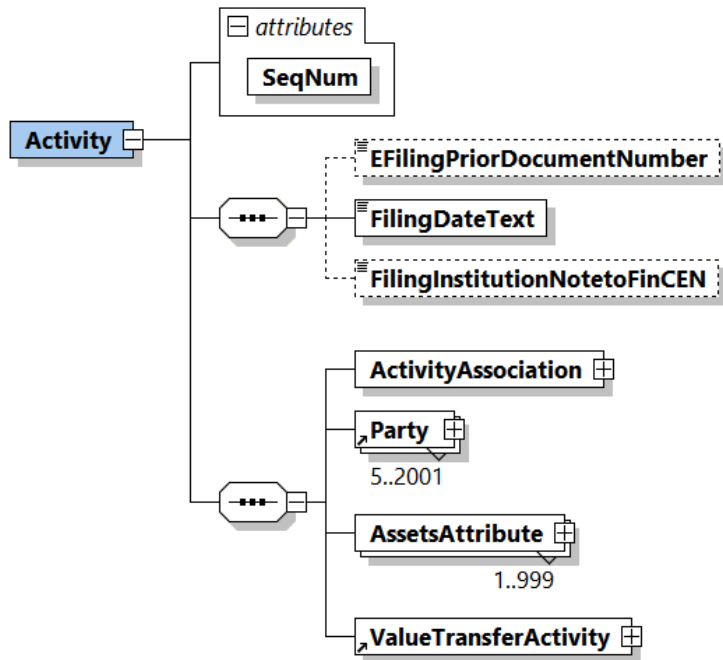

Element	Element Restrictions	Value Restrictions	Item #
<fc2:Activity SeqNum="#">	This element must be recorded at least once in the batch (one per RER). This element is the container for all information about the RER.		
<fc2:E filing Prior Document Number/>	Record this element when the type of filing is "Correct/Amend prior report".	Value must be the 14-digit BSA Identifier (BSA ID) assigned by FinCEN to the RER that is being corrected/amended. The BSA Identifier is delivered to the submitter's secure mailbox on BSA E-Filing via the submission's	Item 1. (b)(i) Prior BSA Identifier (BSA ID)

Element	Element Restrictions	Value Restrictions	Item #
		acknowledgement.	
<fc2:FilingDateText/>	This element must be recorded with the date on which the report is prepared within the XML batch.	Value must be in the format YYYYMMDD where YYYY=century (20) and year (25-99); MM=month (01-12); and DD=day (01-31). Must be a valid date (e.g., 20250231 is invalid because there are not 31 days in February). Cannot be a future date. Cannot be less than the effective date of the RRE rule (12/01/2025).	Item 2. Date prepared
<fc2:FilingInstitutionNotetoFinCEN/>	Do not record this element unless otherwise instructed by FinCEN.	Value must be 35 characters or less.	Item 3. Note to FinCEN
<fc2:ActivityAssociation SeqNum="#">...</fc2:ActivityAssociation>	This element must be recorded once per RER. This element is the container for the type of filing. For details about this element, see ActivityAssociation .		
<fc2:Party SeqNum="#">...</fc2:Party>	This element must be recorded once per RER. This element is the container for the reporting person (Part I, Items 4-14). For details about this element, see Party: Reporting Person .		
<fc2:Party SeqNum="#">...</fc2:Party>	This element must be recorded at least once per RER. This element is the container for the transferee (Part III, Items 23-38, as well as information about the person(s) associated with the transferee, items 39-60). For details about this element, see Party: Transferee .		
<fc2:Party SeqNum="#">...</fc2:Party>	This element must be recorded at least once per RER. This element is the container for the transferor (Part IV, Items 61-78, as well as information about the trustee(s) associated with the transferor when the transferor is a trust, items 79-94). For details about this element, see Party: Transferor .		
<fc2:Party SeqNum="#">...</fc2:Party>	This element must be recorded once per RER. This element is the container for information about the RER batch Transmitter (for E-Filing administrative purposes).		

Element	Element Restrictions	Value Restrictions	Item #
	For details about this element, see Party: Transmitter .		
<fc2:Party SeqNum="#">...</fc2:Party>	This element must be recorded once per RER. This element is the container for information about the RER batch Transmitter Contact (for E-Filing administrative purposes). For details about this element, see Party: Transmitter Contact		
<fc2:AssetsAttribute SeqNum="#">...</fc2:AssetsAttribute>	This element must be recorded at least once per RER. This element is the container for the property (Part II Items 16-22). For details about this element, see AssetsAttribute .		
<fc2:ValueTransferActivity SeqNum="#">...</fc2:ValueTransferActivity>	This element must be recorded once per RER. This element is the container for information about the payment(s) (Part V, Items 95-97, as well as information about each payment made by or on behalf of the transferee entity/trust, items 98-111). For details about this element, see ValueTransferActivityDetail		
</fc2:Activity>	Closing tag for the RER.		

3.4. ActivityAssociation (Type of Filing)

Hierarchy: [EFilingBatchXML](#) / [Activity](#) / [ActivityAssociation](#)

The ActivityAssociation element is the container for the type of filing (i.e., Initial report, correct/amend prior report, FinCEN directed back-filing) for the RER. This element must only be recorded once per RER.

Element	Element Restrictions	Value Restrictions	Item #
<fc2:ActivityAssociation SeqNum="#">	This element must be recorded once per RER. This element is the container for information about the type of filing. Only one of the three elements below may be recorded with a "Y" value for the RER.		
<fc2:CorrectsAmendsPriorReportIndicator/>	Record this element to indicate that the RER corrects/amends a prior report.	Value must be "Y" or null.	Item 1. Type of filing: (b) Correct/Amend prior report
<fc2:FinCENDirectBackFileIndicator/>	Record this element to indicate that the RER is a FinCEN directed back-filing.	Value must be "Y" or null.	Item 1. Type of filing: (c) FinCEN directed back-filing
<fc2:InitialReportIndicator/>	Record this element to indicate that the RER is an initial report.	Value must be "Y" or null.	Item 1. Type of filing: (a) Initial report
</fc2:ActivityAssociation>	Closing tag for the type of filing.		

3.5. Party (General)

Each RER in the batch is comprised of various Party elements with information about each person (e.g., individual, entity, trust, etc.) involved in the RER. These various Party elements are recorded at specific complex element levels within the RER depending on which person is being recorded. The image below lists all of the various simple and complex elements that may be recorded for a Party element in general; however, the elements that should be recorded will vary depending on which type of party is being recorded (see the following sections for details about each party type).

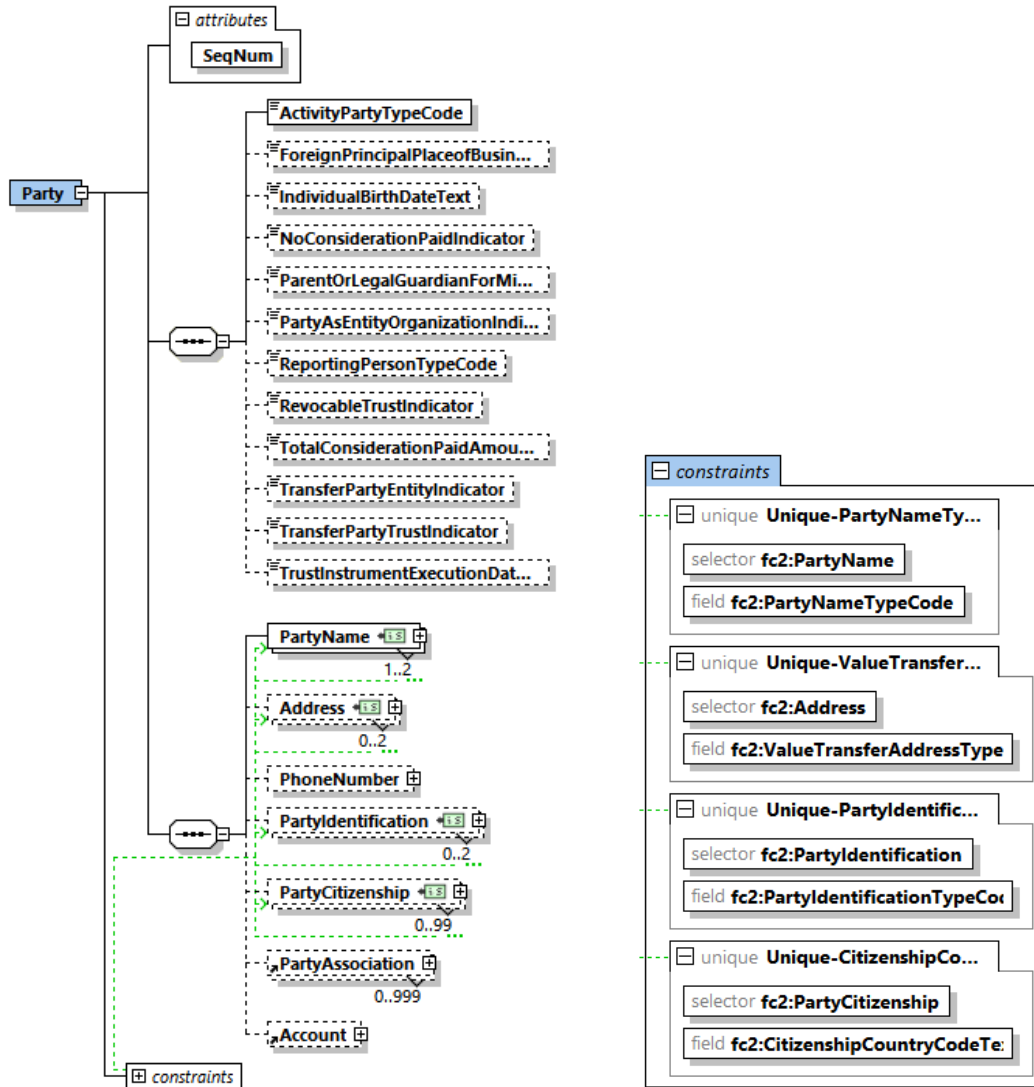

Constraints Defined
<p>The <i>constraints</i> referenced in the RER XML schema are intended to prevent duplicate values at the Party level for four specific elements/scenarios:</p> <ol style="list-style-type: none"> (1) Unique-PartyNameTypeCode: Prevents duplicate name type indicators when recording multiple names for a specific Party type. For example, a Transferee Entity may have two names recorded: Legal name and Alternate name. This constraint ensures that the recording of two legal names or two alternate names for the party is flagged as invalid. (2) Unique-ValueTransferAddressTypeCode: Prevents duplicate address types for a single Party; (3) Unique-PartyIdentificationTypeCode: Prevents duplicate forms of identification for a single Party; (4) Unique-CitizenshipCountryCodeText: Prevents duplicate countries of citizenship for a single beneficial owner Party.

3.5.1. Party: Reporting Person

Hierarchy: [EFilingBatchXML](#) / [Activity](#) / [Party](#)

This Party element is the container for information about the reporting person (individual or entity) recorded in Part I (Items 4-14) of the RER. The reporting person Party element is recorded under the Activity element. The reporting person Party must only be recorded once per RER. The reporting person Party includes the following elements:

Element	Element Restrictions	Value Restrictions	Item #
<fc2:Party SeqNum="#">	This element must be recorded once per RER. This element is the container for information about the reporting person.		
<fc2:ActivityPartyTypeCode/>	This element must be recorded.	Value must be "31" to label this party as the reporting person.	XML
<fc2:PartyAsEntityOrganizationIndicator/>	Record this element to indicate that the reporting person is an entity.	Value must be "Y" or null.	Item 6. If entity
<fc2:ReportingPersonTypeCode/>	This element must be recorded.	Value must be <u>one</u> of the following numeric codes in parentheses: (1) Closing/Settlement agent (2) Closing/Settlement statement preparer (3) Deed/Instrument filer (4) Title insurance underwriter (5) Funds disperser (6) Title evaluation provider (7) Deed/Instrument preparer	Item 4. Reporting person category
<fc2:PartyName SeqNum="#">	This element must be recorded once per reporting person. This element is the container for information about the reporting person's legal name.		
<fc2:PartyNameTypeCode/>	This element must be recorded.	Value must be "L" to associate the name with the reporting person's legal name.	XML

Element	Element Restrictions	Value Restrictions	Item #
<fc2:RawEntityIndividualLastName/>	This element must be recorded.	Value must be 150 characters or less.	Item 5. Last name or entity legal name
<fc2:RawIndividualFirstName/>	Record this element when the reporting person is an individual.	Value must be 35 characters or less.	Item 7. First name
<fc2:RawIndividualMiddleName/>	Record this element when the reporting person is an individual with a middle name.	Value must be 35 characters or less.	Item 8. Middle name
<fc2:RawIndividualNameSuffixText/>	Record this element when the reporting person is an individual with a suffix name.	Value must be 35 characters or less.	Item 9. Suffix
</fc2:PartyName>	Closing tag for the legal name.		
<fc2:Address SeqNum="#">	This element must be recorded once for the reporting person. This element is the container for information about the reporting person's address (U.S. principal place of business).		
<fc2:RawCityText/>	This element must be recorded.	Value must be 50 characters or less.	Item 11. City
<fc2:RawCountryCodeText/>	This element must be recorded.	Value must be "US" (if United States) or the ISO-3166 2-character code associated with a U.S. Territory.	Item 12. U.S./U.S. Territory
<fc2:RawStateCodeText/>	This element must be recorded.	Value must be ISO-3166 2-char U.S. state code (e.g., Virginia = VA), or if in a U.S. Territory, the same ISO-3166 2-char territory code recorded for the RawCountryCodeText must also be recorded here.	Item 13. State/U.S. Territory

Element	Element Restrictions	Value Restrictions	Item #
<fc2:RawStreetAddress1Text/>	This element must be recorded.	Value must be 100 characters or less.	Item 10. Street address (number, street, and apt. or suite no.)
<fc2:RawZIPCode/>	This element must be recorded.	Value must be a valid numeric entry equal to 5 or 9 digits; do not enter "0", all zeros, or 5-digits followed by 4-zeros (e.g. 552140000).	Item 14. ZIP code
</fc2:Address>	Closing tag for the address.		
</fc2:Party>	Closing tag for the reporting person.		

3.5.2. Party: Transferee

Hierarchy: [EFilingBatchXML](#) / [Activity](#) / [Party](#)

This Party is the container for information about the transferee (entity or trust) recorded in Part III (Items 23-38) of the RER. The transferee Party is recorded under the Activity element. The transferee Party must be recorded at least once per RER.

3.5.2.1. If Transferee is an Entity

If the transferee Party is an *entity*, refer to the table below for the list of elements to include for the transferee entity. Please note the following items and corresponding elements are not included in the table below because they are not applicable to a transferee entity:

- Item 23: Transferee type – Trust: TransferPartyTrustIndicator
- Item 24: Date trust instrument executed: TrustInstrumentExecutionDateText
- Item 25: If revocable trust (indicator): RevocableTrustIndicator

Element	Element Restrictions	Value Restrictions	Item #
<fc2:Party SeqNum="#">	This element is the container for information about the transferee entity. Each RER in the batch must contain at least one Party associated with the transferee, whether it be an entity or trust.		
<fc2:ActivityPartyTypeCode/>	This element must be recorded.	Value must be "67" to label this party as the transferee.	XML
<fc2:ForeignPrincipalPlaceofBusinessWithNoUSLocationIndicator/>	Record this element to indicate that the transferee entity has a foreign principal place of business with no U.S. location.	Value must be "Y" or null. If recorded with a "Y" value, then only one address (i.e. the foreign principal place of business) shall be recorded for the transferee entity.	Item 29. Foreign principal place of business with no U.S. location
<fc2:NoConsiderationPaidIndicator/>	Record this element to indicate there is no consideration paid or to be paid, by or on behalf of this transferee.	Value must be "Y" or null.	Item 26. No consideration paid
<fc2:TotalConsiderationPaidAmountText/>	Record this element unless "no consideration paid" is indicated.	Value must be 15 digits or less. Enter amount in whole U.S. dollars (rounded <u>up</u> to the next whole dollar) greater than 0.	Item 26. Total consideration paid (in U.S. dollars)

Element	Element Restrictions	Value Restrictions	Item #
		Example: \$98,015.09 should be rounded up to the next whole dollar and recorded as "98016".	
<fc2:TransferPartyEntityIndicator/>	Record this element to indicate that the transferee is an <u>entity</u> .	Value must be "Y" to indicate the type of transferee as an entity.	Item 23. Transferee type (Entity)
<fc2:PartyName SeqNum="#">	This element must be recorded for the transferee entity. This element is the container for information about the transferee's legal name. Only one legal name is permitted per transferee entity.		
<fc2:PartyNameTypeCode/>	This element must be recorded.	Value must be "L" to associate this name with the transferee's legal name.	XML
<fc2:RawPartyFullName/>	This element must be recorded.	Value must be 150 characters or less.	Item 27. Legal name
</fc2:PartyName>	Closing tag for the legal name.		
<fc2:PartyName SeqNum="#">	Record this element when the transferee entity has an alternate name. Do not record this element if the transferee entity does not have an alternate name. Only one alternate name is permitted per transferee entity.		
<fc2:PartyNameTypeCode/>	This element must be recorded if the parent element is recorded.	Value must be "DBA" to associate the name with the transferee entity's alternate name.	XML
<fc2:RawPartyFullName/>	This element must be recorded if the parent element is recorded.	Value must be 150 characters or less.	Item 28. Alternate name
</fc2:PartyName>	Closing tag for the alternate name.		
<fc2:Address SeqNum="#">	This element must be recorded for the transferee entity. This element is the container for the address associated with transferee entity's principal place of business.		

Element	Element Restrictions	Value Restrictions	Item #
<fc2:RawCityText/>	This element must be recorded.	Value must be 50 characters or less	Item 32. City
<fc2:RawCountryCodeText/>	This element must be recorded.	Value must be ISO-3166 2-char country/jurisdiction code. If U.S. Territory, record the ISO-3166 2-char code associated with a U.S. Territory and record the same U.S. Territory code for the State/U.S. Territory field.	Item 33. Country/Jurisdiction
<fc2:RawStateCodeText/>	Record this element when the associated country/jurisdiction is the United States, a U.S. Territory, Canada, or Mexico.	Value must be ISO-3166 state/territory/province code. If the address is in the United States, then record the 2-char U.S. state code (e.g., Virginia = VA). If the address is in a U.S. Territory, the same ISO-3166 2-char territory code recorded for the RawCountryCodeText must also be recorded here. If the address is in Canada, record the 2-char ISO-3166 Canadian state/province/territory code. If the address is in Mexico, record the 3-char ISO-3166 Mexican state/province/territory code. If the address is in a foreign country/jurisdiction other than Canada or Mexico, do not record this element.	Item 34. State/U.S. Territory
<fc2:RawStreetAddress1Text/>	This element must be recorded.	Value must be 100 characters or less	Item 31. Street address (number, street, and apt. or suite no.)
<fc2:RawZIPCode/>	Record this element when the associated country/jurisdiction is	Value must be a valid numeric entry equal to 5 or 9 digits if the	Item 35. ZIP/Foreign postal code

Element	Element Restrictions	Value Restrictions	Item #
	the United States, a U.S. Territory, Canada, or Mexico. If the associated country/jurisdiction is none of the above, and a foreign postal code does not exist for the address, this element may be omitted for this address.	associated country/jurisdiction is United States (US) or a U.S. Territory. If the address is foreign, then the value may contain alpha and numeric characters up to 9-characters in length. Do not enter "0", all zeros, or 5-digits followed by 4-zeros (e.g. 552140000).	
<fc2:ValueTransferAddressTypeCode/>	This element must be recorded.	Value must be <u>one</u> of the following numeric codes in parentheses: (1) Principal place of business (U.S.) (2) Foreign principal place of business (non-U.S.)	Item 30. Address type
</fc2:Address>	Closing tag for the address (principal place of business).		
<fc2:Address SeqNum="#">	Record this element when the transferee entity has a primary U.S. location where it conducts business in addition to their foreign principal place of business. This element is the container for the address associated with the transferee entity's primary U.S. location where it conducts business. If the transferee entity's principal place of business is in the United States (or U.S. Territory), or if the principal place of business is foreign and the entity does not have a primary U.S. location where it conducts business, then do not record this element.		
<fc2:RawCityText/>	This element must be recorded if the parent element is recorded.	Value must be 50 characters or less	Item 32. City
<fc2:RawCountryCodeText/>	This element must be recorded if the parent element is recorded.	Value must be "US" (if United States) or the ISO-3166 2-character code associated with a U.S. Territory.	Item 33. Country/Jurisdiction
<fc2:RawStateCodeText/>	This element must be recorded if	Value must be ISO-3166 2-character U.S. state code (e.g.,	Item 34. State/U.S. Territory

Element	Element Restrictions	Value Restrictions	Item #
	the parent element is recorded.	Virginia = VA), or if in a U.S. Territory, the same ISO-3166 2-character territory code recorded for the RawCountryCodeText must also be recorded here.	
<fc2:RawStreetAddress1Text/>	This element must be recorded if the parent element is recorded.	Value must be 100 characters or less	Item 31. Street address (number, street, and apt. or suite no.)
<fc2:RawZIPCode/>	This element must be recorded if the parent element is recorded.	Value must be a valid numeric entry equal to 5 or 9 digits; do not enter "0", all zeros, or 5-digits followed by 4-zeros (e.g. 552140000).	Item 35. ZIP/Foreign postal code
<fc2:ValueTransferAddressTypeCode/>	This element must be recorded if the parent element is recorded.	Value must be "3" to indicate "Primary U.S. location where entity conducts business."	Item 30. Address type
</fc2:Address>	Closing tag for the address (U.S. location).		
<fc2:PartyIdentification SeqNum="#">	This element must be recorded once per transferee entity. This element is the container for information about the transferee entity's identification.		
<fc2:OtherIssuerCountryText/>	Record this element to report the issuing country/jurisdiction when a foreign identification is being reported for the transferee entity.	Value must be the ISO-3166 2-char code associated with the country/jurisdiction that issued the foreign identification.	Item 38. Issuing jurisdiction (if foreign)
<fc2:PartyIdentificationNumberText/>	Record this element unless "No identification" is indicated.	If SSN-ITIN or EIN, then value must be 9 numeric characters; otherwise, a foreign identification number can contain alpha and numeric characters up to 25 characters.	Item 37. Identification number

Element	Element Restrictions	Value Restrictions	Item #
		The value cannot be "0" or all zeros.	
<fc2:PartyIdentificationTypeCode/>	This element must be recorded for the transferee identification type (or to indicate "no identification" if applicable).	Value must be <u>one</u> of the following codes in parentheses: If IRS-TIN, then: (1) SSN-ITIN or (2) EIN If no IRS-TIN, then: (43) Foreign taxpayer identification number If no foreign taxpayer identification number, then: (41) Foreign entity registration number For transferee with no identification, then: (42) No identification	Item 58. Identification type (or to indicated "no identification")
</fc2:PartyIdentification>	Closing tag for the identification.		
<fc2:PartyAssociation SeqNum="#">...</fc2:PartyAssociation>	This element must be recorded <u>at least once</u> per transferee entity in the RER. This element is the container for information about the person (beneficial owner and/or signing individual) associated with the transferee entity recorded in Part III of the RER. This element must be recorded separately for each associated person. For details about this element, see Party: Person Association with the Transferee		
</fc2:Party>	Closing tag for the transferee entity.		

3.5.2.2. If Transferee is a Trust

If the transferee party type is a *trust*, refer to the table below for this list of elements to include for the transferee *trust*. Please note the following items and corresponding elements are not included in the table below because they are not applicable to a transferee *trust*:

- Item 23: Transferee type – Entity: TransferPartyEntityIndicator
- Item 28: Alternate name: PartyName (a 2nd occurrence after legal name)
- Item 29: Foreign principal place of business with no U.S. location (indicator): ForeignPrincipalPlaceofBusinessWithNoUSLocationIndicator
- Items 30-35: Address: Address element and associated sub-elements.

Element	Element Restrictions	Value Restrictions	Item #
<fc2:Party SeqNum="#">	This element is the container for information about the transferee trust. Each RER in the batch must contain at least one Party associated with the transferee, whether it be an entity or trust.		
<fc2:ActivityPartyTypeCode/>	This element must be recorded.	Value must be "67" to label this party as the transferee.	XML
<fc2:NoConsiderationPaidIndicator/>	Record this element to indicate there is no consideration paid or to be paid, by or on behalf of this transferee.	Value must be "Y" or null.	Item 26. No consideration paid
<fc2:RevocableTrustIndicator/>	Record this element when the transferee trust is a revocable trust.	Value must be "Y" or null.	Item 25. If revocable trust
<fc2:TotalConsiderationPaidAmountText/>	Record this element unless "no consideration paid" is indicated.	Value must be 15 digits or less. Enter amount in whole U.S. dollars (rounded up to the next whole dollar) greater than 0. Example: \$98,015.09 should be rounded up to the next whole dollar and recorded as "98016".	Item 26. Total consideration paid (in U.S. dollars)
<fc2:TransferPartyTrustIndicator/>	Record this element to indicate that the transferee is a trust.	Value must be "Y" to indicate the type of transferee as a trust.	Item 23. Transferee type (Trust)

Element	Element Restrictions	Value Restrictions	Item #
<fc2:TrustInstrumentExecutionDateText/>	This element must be recorded for the transferee trust.	Value must be in the format YYYYMMDD where YYYY=year (e.g. 2012). MM=month (01-12), and DD=day (01-31). Must be a valid date (e.g. 19990231 is invalid because there are not 31 days in February). Cannot be a future date.	Item 24. Date trust instrument executed
<fc2:PartyName SeqNum="#">	This element must be recorded once per transferee trust. This element is the container for information about the transferee's legal name. Only one legal name is permitted per transferee trust.		
<fc2:PartyNameTypeCode/>	This element must be recorded.	Value must be "L" to associate the name with the transferee's legal name.	XML
<fc2:RawPartyFullName/>	This element must be recorded.	Value must be 150 characters or less.	Item 27. Legal name
</fc2:PartyName>	Closing tag for the legal name.		
<fc2:PartyIdentification SeqNum="#">	This element must be recorded once per transferee trust. This element is the container for information about the transferee trust's identification.		
<fc2:OtherIssuerCountryText/>	Record this element to report the issuing country/jurisdiction when a foreign identification is being reported for the transferee trust.	Value must be the ISO-3166 2-char code associated with the country/jurisdiction that issued the foreign identification.	Item 38. Issuing jurisdiction (if foreign)
<fc2:PartyIdentificationNumberText/>	Record this element unless "No identification" is indicated.	If SSN-ITIN or EIN, then value must be 9 numeric characters; otherwise, a foreign identification number can contain alpha and numeric characters up to 25 characters.	Item 37. Identification number

Element	Element Restrictions	Value Restrictions	Item #
		The value cannot be "0" or all zeros.	
<fc2:PartyIdentificationTypeCode/>	This element must be recorded for the transferee identification type (or to indicate "no identification" if applicable).	Value must be <u>one</u> of the following codes in parentheses: If IRS-TIN, then: (1) SSN-ITIN or (2) EIN If no IRS-TIN, then: (43) Foreign taxpayer identification number For transferee trust with no identification, then: (42) No identification	Item 58. Identification type (or to indicated "no identification")
</fc2:PartyIdentification>	Closing tag for the identification.		
<fc2:PartyAssociation SeqNum="#">...</fc2:PartyAssociation>	This element must be recorded <u>at least once</u> per transferee <i>trust</i> in the RER. This element is the container for information about the person (beneficial owner and/or signing individual, or trustee legal entity) associated with the transferee trust recorded in Part III of the RER. This element must be recorded separately for each associated person. For details about this element, see Party: Person Association with the Transferee		
</fc2:Party>	Closing tag for the Transferee Trust.		

3.5.2.3. Party: Person Associated with the Transferee

Hierarchy: *EfilingBatchXML / Activity / Party / **PartyAssociation** / Party*

This is the person (beneficial owner and/or signing individual, or trustee legal entity) recorded in Part III (items 39-60) of the RER. The associated person party must be recorded at least once per transferee (entity or trust) in the RER.

3.5.2.3.1. *If Associated Person is a Beneficial Owner and/or Signing Individual*

If, in relation to the transferee (entity or trust), the associated person is a beneficial owner and signing individual, the party will include all of the elements from the table below; however, if the associated person is only a beneficial owner or only a signing individual, then only the elements relevant to that person type (noted in the element restrictions below) may be recorded.

Please note the following items and corresponding elements are not included in the table below because they are not applicable to a beneficial owner or signing individual:

- Item 39: Person type – Trustee Legal Entity: TrusteeIndicator
- Item 46: Alternate name: PartyName (a 2nd occurrence after legal name)
- Item 51: Foreign principal place of business with no U.S. location (indicator): ForeignPrincipalPlaceofBusinessWithNoUSLocationIndicator
- Item 52: Address type: ValueTransferAddressTypeCode
- A 2nd set of Address Items 53-57 (only a single residential address may be recorded for a beneficial owner and/or signing individual): Address (and associated sub-elements)
- Item 58 Identification type “Foreign entity registration number” and “No identification” selections (these identification types are only applicable to trustee legal entity from an associated person perspective): PartyIdentificationTypeCode

Element	Element Restrictions	Value Restrictions	Item #
<fc2:PartyAssociation SeqNum="#">	This element must be recorded separately for each person associated with the transferee—specifically, a beneficial owner or signing individual. However, if the person is both a beneficial owner and signing individual, this element can be recorded once with both indicators (beneficial owner and signing individual) selected. This element is the container for information about the beneficial owner and/or signing individual.		
<fc2:BeneficialOwnerAuthorityDisposeAssetsIndicator/>	If this person is a beneficial owner and the associated transferee is a trust, record this element if this category of beneficial owner is applicable. More than one category may be	Value must be “Y” or null.	Item 41. Beneficial owner category: (f) Beneficial owner of a legal entity or trust with authority to dispose of assets

Element	Element Restrictions	Value Restrictions	Item #
	indicated.		
<fc2:BeneficialOwnerGrantorSettlorRightRevokeWithdrawAssetsIndicator/>	If this person is a beneficial owner and the associated transferee is a trust, record this element if this category of beneficial owner is applicable. More than one category may be indicated.	Value must be "Y" or null.	Item 41. Beneficial owner category: (h) Beneficial owner of legal entity or trust that is a grantor or settlor with the right to revoke or withdraw assets
<fc2:BeneficialOwnerIndicator/>	Record this element to indicate the type of associated person being recorded as a beneficial owner. NOTE: If the beneficial owner is also the signing individual, the SigningIndividualIndicator may also be indicated.	Value must be "Y" or null.	Item 39. Person type: (a) Beneficial Owner
<fc2:BeneficialOwnerSolePermissibleRecipientTrustIncomeAsstsIndicator/>	If this person is a beneficial owner and the associated transferee is a trust, record this element if this category of beneficial owner is applicable. More than one category may be indicated.	Value must be "Y" or null.	Item 41. Beneficial owner category: (g) Beneficial owner of a legal entity or trust that is the sole permissible recipient of trust income or assets
<fc2:BeneficialOwnerTrusteeIndicator/>	If this person is a beneficial owner and the associated transferee is a trust, record this element if this category of beneficial owner is applicable. More than one category may be indicated.	Value must be "Y" or null.	Item 41. Beneficial owner category: (e) Beneficial owner of a legal entity or trust that is a trustee

Element	Element Restrictions	Value Restrictions	Item #
<fc2:GrantorSettlorRightRevokeWithdrawAssets Indicator/>	If this person is a beneficial owner and the associated transferee is a trust, record this element if this category of beneficial owner is applicable. More than one category may be indicated.	Value must be "Y" or null.	Item 41. Beneficial owner category: (d) Grantor or settlor with the right to revoke or withdraw assets
<fc2:IndividualAuthorityDisposeAssetsIndicator/>	If this person is a beneficial owner and the associated transferee is a trust, record this element if this category of beneficial owner is applicable. More than one category may be indicated.	Value must be "Y" or null.	Item 41. Beneficial owner category: (b) Individual with authority to dispose of assets
<fc2:IndividualTrusteeIndicator/>	If this person is a beneficial owner and the associated transferee is a trust, record this element if this category of beneficial owner is applicable. More than one category may be indicated.	Value must be "Y" or null.	Item 41. Beneficial owner category: (a) Individual trustee
<fc2:SigningIndividualIndicator/>	Record this element to indicate the type of associated person being recorded as a signing individual. NOTE: If the signing individual is also a beneficial owner, the BeneficialOwnerIndicator may also be indicated.	Value must be "Y" or null.	Item 39. Person type: (b) Signing Individual
<fc2:SolePermissibleRecipientTrustIncomeAssetIndicator/>	If this person is a beneficial owner and the associated transferee is a trust, record this element if this category of	Value must be "Y" or null.	Item 41. Beneficial owner category: (c) Sole permissible recipient of trust income or

Element	Element Restrictions	Value Restrictions	Item #
	beneficial owner is applicable. More than one category may be indicated.		assets
<fc2:Party SeqNum="#">	This element must be recorded once per PartyAssociation element. This element is the container for information about the person associated with the transferee (i.e. the Beneficial Owner and/or Signing Individual).		
<fc2:ActivityPartyTypeCode/>	This element must be recorded.	Value must be "68" to label this party as the person associated with the transferee.	XML
<fc2:IndividualBirthDateText/>	This element must be recorded.	Value must be in the format YYYYMMDD where YYYY=year (e.g. 1978). MM=month (01-12), and DD=day (01-31). Must be a valid date (e.g. 19990231 is invalid because there are not 31 days in February). Cannot be a future date.	Item 50. Date of birth
<fc2:ParentOrLegalGuardianForMinorChildIndicator/>	Record this element if the parent/guardian's information is recorded instead of the minor child beneficial owner. Do not record this element if the person is a signing individual (only).	Value must be "Y" or null.	Item 40. Parent/guardian information instead of minor child
<fc2:PartyName SeqNum="#">	This element must be recorded once per beneficial owner/signing individual. This element is the container for information about the associated person's legal name.		
<fc2:PartyNameTypeCode/>	This element must be recorded.	Value must be "L" to associate the name with the associated person's legal name.	XML
<fc2:RawEntityIndividualLastName/>	This element must be recorded.	Value must be 150 characters or less.	Item 45. Last name or entity legal name

Element	Element Restrictions	Value Restrictions	Item #
<fc2:RawIndividualFirstName/>	This element must be recorded.	Value must be 35 characters or less.	Item 47. First name
<fc2:RawIndividualMiddleName/>	Record this element if the beneficial owner and/or signing individual has a middle name.	Value must be 35 characters or less.	Item 48. Middle name
<fc2:RawIndividualNameSuffixText/>	Record this element when the beneficial owner and/or signing individual has a suffix name.	Value must be 35 characters or less.	Item 49. Suffix
</fc2:PartyName>	Closing tag for the legal name.		
<fc2:Address SeqNum="#">	This element must be recorded once per beneficial owner/signing individual. This element is the container for information about the associated person's residential address.		
<fc2:RawCityText/>	This element must be recorded.	Value must be 50 characters or less	Item 54. City
<fc2:RawCountryCodeText/>	This element must be recorded.	Value must be ISO-3166 2-char country/jurisdiction code. If U.S. Territory, record the ISO-3166 2-char code associated with a U.S. Territory and record the same U.S. Territory code for the State/U.S. Territory field.	Item 55. Country/Jurisdiction
<fc2:RawStateCodeText/>	Record this element when the associated country/jurisdiction is the United States, a U.S. Territory, Canada, or Mexico; otherwise, do not record this element.	Value must be ISO-3166 code. If the address is in the United States, then record the 2-char U.S. state code. If the address is in a U.S. Territory, the same ISO-3166 2-character territory code recorded for the country must also be recorded here. If the address is in Canada, record the	Item 56. State/U.S. Territory

Element	Element Restrictions	Value Restrictions	Item #
		2-char Canadian state/province/territory code. If the address is in Mexico, record the 3-char Mexican state/province/territory code. If the address is in a foreign country/jurisdiction other than Canada or Mexico, do not record this element.	
<fc2:RawStreetAddress1Text/>	This element must be recorded.	Value must be 100 characters or less	Item 53. Street address (number, street, and apt. or suite no.)
<fc2:RawZIPCode/>	Record this element when the associated country/jurisdiction is the United States, a U.S. Territory, Canada, or Mexico. If the associated country/jurisdiction is none of the above, record this element for the foreign postal code only if available.	Value must be a valid numeric entry equal to 5 or 9 digits if the associated country/jurisdiction is United States or a U.S. Territory. If the associated country/jurisdiction is foreign, then the value may contain alpha and numeric up to 9-characters. In either scenario, do not enter "0", all zeros, or 5-digits followed by 4-zeros (e.g. 552140000).	Item 57. ZIP/Foreign postal code
</fc2:Address>	Closing tag for the address (residential).		
<fc2:PartyIdentification SeqNum="#">	This element must be recorded once per associated person. This element is the container for information about the associated person's identification.		
<fc2:OtherIssuerCountryText/>	Record this element when a foreign identification is recorded.	Value must be the ISO-3166 2-char code associated with the country/jurisdiction that issued the foreign identification.	Item 60. Issuing jurisdiction (if foreign)
<fc2:PartyIdentificationNumberText/>	Record this element unless "No	If SSN-ITIN or EIN, then value must be 9 numeric characters;	Item 59. Identification number

Element	Element Restrictions	Value Restrictions	Item #
	identification" is indicated.	otherwise, a foreign identification number can contain alpha and numeric characters up to 25 characters. The value cannot be "0" or all zeros.	
<fc2:PartyIdentificationTypeCode/>	This element must be recorded for the associated person identification type.	Value must be one of the following codes in parentheses (indicate one): If IRS-TIN, then: (1) SSN-ITIN or (2) EIN If no IRS-TIN, then: (43) Foreign taxpayer identification number If no foreign taxpayer identification number, then: (40) Foreign passport.	Item 58. Identification type
</fc2:PartyIdentification>	Closing tag for the identification.		
<fc2:PartyCitizenshipSeqNum="#">	Record this element if the associated person is a beneficial owner. This element is the container for the beneficial owner's country/jurisdiction of citizenship. This element may be recorded multiple times if the beneficial owner has more than one country/jurisdiction of citizenship. If the associated person is a signing individual (only), then do not record this element		
<fc2:CitizenshipCountryCodeText/>	This element must be recorded if the parent element is recorded.	Value must be the ISO-3166 2-char code associated with the beneficial owner's country/jurisdiction of citizenship.	Item 42. Country/Jurisdiction of citizenship
</fc2:PartyCitizenship>	Closing tag for the beneficial owner's country/jurisdiction of citizenship.		
<fc2:PartyAssociationSeqNum="#">	Record this element if the associated person is a signing individual. This element is the container for the signing individual's authorization capacity and to record the name of the individual's employer, principal, or partnership. This element may only be recorded once per signing individual associated person. If the		

Element	Element Restrictions	Value Restrictions	Item #
	associated person is a beneficial owner (only), then do not record this element.		
<fc2:AgentIndicator/>	If the associated person is a signing individual, record this element if this authorization capacity is applicable. Only one authorization capacity may be indicated.	Value must be "Y" or null.	Item 43. [Signing Individual] Authorization capacity: (b) Agent
<fc2:CounselIndicator/>	If the associated person is a signing individual, record this element if this authorization capacity is applicable. Only one authorization capacity may be indicated.	Value must be "Y" or null.	Item 43. [Signing Individual] Authorization capacity: (e) Counsel
<fc2:EmployeeIndicator/>	If the associated person is a signing individual, record this element if this authorization capacity is applicable. Only one authorization capacity may be indicated.	Value must be "Y" or null.	Item 43. [Signing Individual] Authorization capacity: (a) Employee
<fc2:OfficerIndicator/>	If the associated person is a signing individual, record this element if this authorization capacity is applicable. Only one authorization capacity may be indicated.	Value must be "Y" or null.	Item 43. [Signing Individual] Authorization capacity: (d) Officer
<fc2:OtherPartyAssociationTypeText/>	If the associated person is a signing individual, record this element if "Other" is indicated as the authorization capacity; otherwise, do not record this element.	Value must be 50 characters or less	Item 43. [Signing Individual] Authorization capacity: (g) Other - description

Element	Element Restrictions	Value Restrictions	Item #
<fc2:OtherRelationshipIndicator/>	If the associated person is a signing individual, record this element if this authorization capacity is applicable. Only one authorization capacity may be indicated.	Value must be "Y" or null.	Item 43. [Signing Individual] Authorization capacity: (g) Other
<fc2:PartnerIndicator/>	If the associated person is a signing individual, record this element if this authorization capacity is applicable. Only one authorization capacity may be indicated.	Value must be "Y" or null.	Item 43. [Signing Individual] Authorization capacity: (c) Partner
<fc2:TrusteeIndicator/>	If the associated person is a signing individual, record this element if this authorization capacity is applicable. Only one authorization capacity may be indicated.	Value must be "Y" or null.	Item 43. [Signing Individual] Authorization capacity: (f) Trustee
<fc2:Party SeqNum="#">...</fc2:Party>	If the associated person is a signing individual, record this element as the container for information about the Item 44 employer, principal, or partnership associated with the signing individual; however, if "Other" is indicated as the authorization capacity (Item 43), Item 44 may be left empty if the information is not applicable – and as a result, this party element would not be recorded (see Party: Item 44 Person Association with Signing Individual for details).		
</fc2:Party>	Closing tag for the associated person.		
</fc2:PartyAssociation>	Closing tag for the associated person type (and beneficial owner category).		

3.5.2.3.1.1. Party: Person Associated with Signing Individual (Item 44)

If a signing individual is recorded, the name of their employer, principal, or partnership is recorded unless "Other" is indicated as their authorization capacity, in which case this particular party (associated with Item 44) is not required if this information is not applicable.

Element	Element Restrictions	Value Restrictions	Item #
<fc2:Party SeqNum="#">	If the associated person is a signing individual, record this element as the container for information about the employer, principal, or partnership associated with the signing individual. However, if "Other" is indicated as the authorization capacity, Item 44 may be left empty if not applicable, and as a result, this element would not be recorded.		
<fc2:ActivityPartyTypeCode/>	This element must be recorded if the parent element is recorded.	Value must be "73" to label this party as the signing individual's employer, principal, or partnership	XML
<fc2:PartyName SeqNum="#">	This element must be recorded if the parent element is recorded. This element is the container for the signing individual's employer, principal, or partnership legal name.		
<fc2:PartyNameTypeCode/>	This element must be recorded if the parent element is recorded.	Value must be "L" to associate the name with legal name of the signing individual's employer, principal, or partnership.	XML
<fc2:RawPartyFullName/>	This element must be recorded if the parent element is recorded.	Value must be 150 characters or less.	Item 44. Name of employer, principal, or partnership
</fc2:PartyName>	Closing tag for the legal name.		
</fc2:Party>	Closing tag for the person associated with signing individual.		

3.5.2.3.2. If Associated Person is a Trustee Legal Entity

If, in relation to the transferee trust, the associated person is a *trustee legal entity*, the party will include the elements from the table below.

Please note the following items and corresponding elements that are not included in the table below because they are not applicable to a trustee legal entity:

- Item 39: Person Type – Beneficial Owner (BeneficialOwnerIndicator) and Signing Individual (SigningIndividualIndicator)
- Item 40: [Beneficial owner] Parent/Guardian information instead of minor child (indicator) (ParentOrLegalGuardianForMinorChildIndicator)
- Item 41: [Beneficial owner] Category (indicators):
 - BeneficialOwnerAuthorityDisposeAssetsIndicator
 - BeneficialOwnerGrantorSettlorRightRevokeWithdrawAssetsIndicator
 - BeneficialOwnerSolePermissibleRecipientTrstIncomeAsstsIndicator
 - BeneficialOwnerTrusteeIndicator
 - GrantorSettlorRightRevokeWithdrawAssetsIndicator
 - IndividualAuthorityDisposeAssetsIndicator
 - IndividualTrusteeIndicator
 - SolePermissibleRecipientTrustIncomeAssetsIndicator
- Item 42: [Beneficial owner] Country/Jurisdiction of citizenship (PartyCitizenship/CitizenshipCountryCodeText)
- Item 43: [Signing individual] Authorization capacity: PartyAssociation (and all associated sub-elements)
- Items 47-49: First name (RawIndividualFirstName), middle name (RawIndividualMiddleName), and suffix (RawIndividualNameSuffixText)
- Item 50: Date of birth (IndividualBirthDateText)
- Item 58: Identification type – “Foreign passport” selection (PartyIdentificationTypeCode=40) as this identification type is only applicable to a beneficial owner and/or signing individual from an associated person perspective.

Element	Element Restrictions	Value Restrictions	Item #
<fc2:PartyAssociation SeqNum="#">	This element must be recorded separately for each person associated with the transferee trust, specifically, a trustee legal entity. This element is the container for information about the trustee legal entity. If the associated transferee is an entity, then the associated person cannot be a trustee legal entity.		
<fc2:TrusteeIndicator/>	When this person is a trustee legal entity, record this element to indicate the person type as a trustee legal entity.	Value must be “Y” or null.	Item 39. Person type: (c) Trustee Legal Entity
<fc2:Party SeqNum="#">	This element must be recorded once per PartyAssociation element. This element is the container for information about the person associated with the transferee trust (i.e. trustee legal entity).		

Element	Element Restrictions	Value Restrictions	Item #
<fc2:ActivityPartyTypeCode/>	This element must be recorded.	Value must be "68" to label this party as the person associated with the transferee.	XML
<fc2:ForeignPrincipalPlaceofBusinessWithNoUSLocationIndicator/>	Record this element when the associated person is a trustee legal entity that has a foreign principal place of business with no U.S. location. As a result, only the one address associated with the foreign principal place of business shall be recorded for this person.	Value must be "Y" or null. If recorded with a "Y" value, then only one address (i.e. the foreign principal place of business) shall be recorded for the associated person trustee legal entity.	Item 51. Foreign principal place of business with no U.S. location
<fc2:PartyName SeqNum="#">	This element must be recorded for the trustee legal entity. This element is the container for information about the trustee's legal name.		
<fc2:PartyNameTypeCode/>	This element must be recorded.	Value must be "L" to associate the name with the associated person's legal name.	XML
<fc2:RawEntityIndividualLastName/>	This element must be recorded for the trustee legal entity's legal name.	Value must be 150 characters or less.	Item 45. Last name or entity legal name
</fc2:PartyName>	Closing tag for legal name.		
<fc2:PartyName SeqNum="#">	Record this element when the associated person is a trustee legal entity and the entity has an alternate name. Do not record this element if the trustee legal entity does not have an alternate name.		
<fc2:PartyNameTypeCode/>	This element must be recorded if the parent element is recorded.	Value must be "DBA" to associate the name with the associated person's alternate name.	XML

Element	Element Restrictions	Value Restrictions	Item #
<fc2:RawPartyFullName/>	This element must be recorded if the parent element is recorded.	Value must be 150 characters or less.	Item 46. Alternate name
</fc2:PartyName>	Closing tag for alternate name.		
<fc2:Address SeqNum="#">	This element must be recorded. This element is the container for the trustee legal entity's principal place of business.		
<fc2:RawCityText/>	This element must be recorded.	Value must be 50 characters or less	Item 54. City
<fc2:RawCountryCodeText/>	This element must be recorded.	Value must be ISO-3166 2-char country/jurisdiction code. If U.S. Territory, record the ISO-3166 2-char code associated with a U.S. Territory and record the same U.S. Territory code for the State/U.S. Territory field.	Item 55. Country/Jurisdiction
<fc2:RawStateCodeText/>	Record this element when the associated country/jurisdiction is the United States, a U.S. Territory, Canada, or Mexico; otherwise, do not record this element.	Value must be ISO-3166 code. If the address is in the United States, then record the 2-char U.S. state code. If the address is in a U.S. Territory, the same ISO-3166 2-character territory code recorded for the country must also be recorded here. If the address is in Canada, record the 2-char Canadian state/province/territory code. If the address is in Mexico, record the 3-char Mexican state/province/territory code. If the address is in a foreign country/jurisdiction other than	Item 56. State/U.S. Territory

Element	Element Restrictions	Value Restrictions	Item #
		Canada or Mexico, do not record this element.	
<fc2:RawStreetAddress1Text/>	This element must be recorded.	Value must be 100 characters or less	Item 53. Street address (number, street, and apt. or suite no.)
<fc2:RawZIPCode/>	Record this element when the associated country/jurisdiction is the United States, a U.S. Territory, Canada, or Mexico. If the associated country/jurisdiction is none of the above, record this element for the foreign postal code only if available.	Value must be a valid numeric entry equal to 5 or 9 digits if the associated country/jurisdiction is United States or a U.S. Territory. If the associated country/jurisdiction is foreign, then the value may contain alpha and numeric up to 9-characters. In either scenario, do not enter "0", all zeros, or 5-digits followed by 4-zeros (e.g. 552140000).	Item 57. ZIP/Foreign postal code
<fc2:ValueTransferAddressTypeCode/>	This element must be recorded.	Value must be one of the following codes in parentheses (indicate one): (1) Principal place of business (U.S.) (2) Foreign principal place of business (non-U.S.)	Item 52. Address type
</fc2:Address>	Closing tag for address (principal place of business).		
<fc2:Address SeqNum="#">	Record this element when the entity has a primary U.S. location where it conducts business in addition to their foreign principal place of business. This element is the container for the address associated with the entity's primary U.S. location where it conducts business. If the entity's principal place of business is in the United States, or if the principal place of business is foreign and it does not have a primary U.S. location where it conducts business, then do not record this element.		
<fc2:RawCityText/>	This element must be recorded if the parent element is	Value must be 50 characters or less	Item 54. City

Element	Element Restrictions	Value Restrictions	Item #
	recorded.		
<fc2:RawCountryCodeText/>	This element must be recorded if the parent element is recorded.	Value must be "US" (if United States) or the ISO-3166 2-character code associated with a U.S. Territory.	Item 55. Country/Jurisdiction
<fc2:RawStateCodeText/>	This element must be recorded if the parent element is recorded.	Value must be ISO-3166 2-character U.S. state code, or if in a U.S. Territory, the same ISO-3166 2-character territory code recorded for the country must also be recorded here.	Item 56. State/U.S. Territory
<fc2:RawStreetAddress1Text/>	This element must be recorded if the parent element is recorded.	Value must be 100 characters or less	Item 53. Street address (number, street, and apt. or suite no.)
<fc2:RawZIPCode/>	This element must be recorded if the parent element is recorded.	Value must be a valid numeric entry equal to 5 or 9 digits; do not enter "0", all zeros, or 5-digits followed by 4-zeros (e.g. 552140000).	Item 57. ZIP/Foreign postal code
<fc2:ValueTransferAddressTypeCode/>	This element must be recorded if the parent element is recorded.	Value must be "3" to indicate "Primary U.S. location where entity conducts business."	Item 52. Address type
</fc2:Address>	Closing tag for address (primary U.S. location).		
<fc2:PartyIdentification SeqNum="#">	This element must be recorded once per associated person. This element is the container for information about the associated person's identification.		
<fc2:OtherIssuerCountryText/>	Record this element when a foreign identification is	Value must be the ISO-3166 2-char code associated with the country/jurisdiction that issued	Item 60. Issuing jurisdiction (if foreign)

Element	Element Restrictions	Value Restrictions	Item #
	recorded.	the foreign identification.	
<fc2:PartyIdentificationNumberText/>	Record this element unless "No identification" is indicated.	If SSN-ITIN or EIN, then value must be 9 numeric characters; otherwise, a foreign identification number can contain alpha and numeric characters up to 25 characters. The value cannot be "0" or all zeros.	Item 59. Identification number
<fc2:PartyIdentificationTypeCode/>	This element must be recorded for the associated person identification type (or to indicate "no identification" if applicable).	Value must be one of the following codes in parentheses (indicate one): If IRS-TIN, then: (1) SSN-ITIN or (2) EIN If no IRS-TIN, then: (43) Foreign taxpayer identification number If no foreign taxpayer identification number, then: (41) Foreign entity registration number For trustee entity with no identification, then: (42) No identification	Item 58. Identification type or "No identification"
</fc2:PartyIdentification>	Closing tag for identification.		
</fc2:Party>	Closing tag for Trustee legal entity.		
</fc2:PartyAssociation>	Closing tag for Associated person type.		

3.5.3. Party: Transferor

Hierarchy: [EFilingBatchXML](#) / [Activity](#) / [Party](#)

This party is the container for information about the transferor (individual, entity, or trust) recorded in Part IV (Items 61-78) of the RER. The transferor party type must be recorded at least once per RER in the batch.

3.5.3.1. If Transferor is an Individual or an Entity

If the transferor party type is an *individual* or an *entity*, the party will include the elements from the table below (refer to the element restrictions to determine which specific elements to record for either type). Please note the following items and corresponding elements that are not included in the table below because they are not applicable to a transferee *individual* or *entity*:

- Item 61: Transferor type – Trust: TransferPartyTrustIndicator
- Item 62: Date trust instrument executed: TrustInstrumentExecutionDateText
- Items 79-94: Trustee Information (because a trustee may only be recorded for a transferor when the transferor is a trust): PartyAssociation/Party

Element	Element Restrictions	Value Restrictions	Item #
<fc2:Party SeqNum="#">	This element must be recorded at least once per RER. This element is the container for information about a transferor that is an individual or entity. The elements recorded for the transferor will depend on which type is being recorded.		
<fc2:ActivityPartyTypeCode/>	This element must be recorded.	Value must be "69" to label this party as the transferor.	XML
<fc2:ForeignPrincipalPlaceofBusinessWithNoUSLocationIndicator/>	Record this element when the transferor is an entity and has a foreign principal place of business with no U.S. location.	Value must be "Y" or null. If recorded with a "Y" value, then only one address (i.e. the foreign principal place of business) shall be recorded for the transferor entity.	Item 69. Foreign principal place of business with no U.S. location
<fc2:IndividualBirthDateText/>	Record this element when the transferor is an individual.	Value must be in the format YYYYMMDD where YYYY=year (e.g. 1978). MM=month (01-12), and DD=day (01-31). Must be a valid date (e.g. 19990231 is invalid because there are not 31 days in February). Cannot be a	Item 68. Date of birth

Element	Element Restrictions	Value Restrictions	Item #
		future date.	
<fc2:TransferPartyEntityIndicator/>	Record this element when the transferor is an entity.	Value must be "Y" to indicate the type of transferor as an entity.	Item 61. Transferor type (Entity)
<fc2:PartyName SeqNum="#">	This element must be recorded once per transferor. This element is the container for information about the transferor's legal name.		
<fc2:PartyNameTypeCode/>	This element must be recorded.	Value must be "L" to associate the name with the transferor's legal name.	XML
<fc2:RawEntityIndividualLastName/>	This element must be recorded.	Value must be 150 characters or less.	Item 63. Last name or entity legal name
<fc2:RawIndividualFirstName/>	Record this element when the transferor is an individual.	Value must be 35 characters or less.	Item 65. First name
<fc2:RawIndividualMiddleName/>	Record this element when the transferor is an individual and they have a middle name.	Value must be 35 characters or less.	Item 66. Middle name
<fc2:RawIndividualNameSuffixText/>	Record this element when the transferor is an individual and they have a suffix name.	Value must be 35 characters or less.	Item 67. Suffix
</fc2:PartyName>	Closing tag for legal name.		
<fc2:PartyName SeqNum="#">	Record this element when the transferor is an entity and the entity has an alternate name. Do not record this element if the transferor entity does not have an alternate name or if the transferor is an individual.		
<fc2:PartyNameTypeCode/>	This element must be recorded if the parent element is recorded.	Value must be "DBA" to associate the name with the transferor entity's alternate name.	XML

Element	Element Restrictions	Value Restrictions	Item #
<fc2:RawPartyFullName/>	This element must be recorded if the parent element is recorded.	Value must be 150 characters or less.	Item 64. Alternate name
</fc2:PartyName>	Closing tag for alternate name.		
<fc2:Address SeqNum="#">	This element must be recorded for the transferor individual or entity. If the transferor is an entity, then this element is the container for the address associated with entity's principal place of business. If the transferor is an individual, then this element is the container for the individual's residential address.		
<fc2:RawCityText/>	This element must be recorded.	Value must be 50 characters or less	Item 72. City
<fc2:RawCountryCodeText/>	This element must be recorded.	Value must be ISO-3166 2-char country/jurisdiction code. If U.S. Territory, record the ISO-3166 2-char code associated with a U.S. Territory and record the same U.S. Territory code for the State/U.S. Territory field.	Item 73. Country/Jurisdiction
<fc2:RawStateCodeText/>	Record this element when the associated country/jurisdiction is the United States, a U.S. Territory, Canada, or Mexico.	Value must be ISO-3166 code. If the address is in the United States, then record the 2-char U.S. state code. If the address is in a U.S. Territory, the same ISO-3166 2-character territory code recorded for the country must also be recorded here. If the address is in Canada, record the 2-char Canadian state/province/territory code. If the address is in Mexico, record the 3-char Mexican state/province/territory code. If the address is in a foreign country/jurisdiction other than	Item 74. State/U.S. Territory

Element	Element Restrictions	Value Restrictions	Item #
		Canada or Mexico, do not record this element.	
<fc2:RawStreetAddress1Text/>	This element must be recorded.	Value must be 100 characters or less	Item 71. Street address (number, street, and apt. or suite no.)
<fc2:RawZIPCode/>	Record this element when the associated country/jurisdiction is the United States, a U.S. Territory, Canada, or Mexico. If the associated country/jurisdiction is none of the above, the element need not be recorded if a foreign postal code is not applicable.	Value must be a valid numeric entry equal to 5 or 9 digits if the associated country/jurisdiction is United States or a U.S. Territory. If the associated country/jurisdiction is foreign, then the value may contain alpha and numeric up to 9-characters. In either scenario, do not enter "0", all zeros, or 5-digits followed by 4-zeros (e.g. 552140000).	Item 75. ZIP/Foreign postal code
<fc2:ValueTransferAddressTypeCode/>	Record this element when the transferor is an entity.	Value must be one of the following codes in parentheses (indicate one): (1) Principal place of business (U.S.) (2) Foreign principal place of business (non-U.S.)	Item 70. Address type
</fc2:Address>	Closing tag for address (principal place of business or residential).		
<fc2:Address SeqNum="#">	Record this element when the transferor is an entity and the entity has a primary U.S. location where it conducts business in addition to their foreign principal place of business. This element is the container for the address associated with the entity's primary U.S. location where it conducts business. If the transferor entity's principal place of business is in the United States – or if the principal place of business is foreign and it does not have a primary U.S. location where it conducts business – then do not record this element. Do not record this element if the transferor is an individual.		

Element	Element Restrictions	Value Restrictions	Item #
<fc2:RawCityText/>	This element must be recorded if the parent element is recorded.	Value must be 50 characters or less	Item 72. City
<fc2:RawCountryCodeText/>	This element must be recorded if the parent element is recorded.	Value must be "US" (if United States) or the ISO-3166 2-character code associated with a U.S. Territory.	Item 73. Country/Jurisdiction
<fc2:RawStateCodeText/>	This element must be recorded if the parent element is recorded.	Value must be ISO-3166 2-character U.S. state code, or if in a U.S. Territory, the same ISO-3166 2-character territory code recorded for the country must also be recorded here.	Item 74. State/U.S. Territory
<fc2:RawStreetAddress1Text/>	This element must be recorded if the parent element is recorded.	Value must be 100 characters or less	Item 71. Street address (number, street, and apt. or suite no.)
<fc2:RawZIPCode/>	This element must be recorded if the parent element is recorded.	Value must be a valid numeric entry equal to 5 or 9 digits; do not enter "0", all zeros, or 5-digits followed by 4-zeros (e.g. 552140000).	Item 75. ZIP/Foreign postal code
<fc2:ValueTransferAddressTypeCode/>	This element must be recorded if the parent element is recorded.	Value must be "3" to indicate "Primary U.S. location where entity conducts business."	Item 70. Address type
</fc2:Address>	Closing tag for address (primary U.S. location).		
<fc2:PartyIdentification SeqNum="#">	This element must be recorded once per transferor. This element is the container for information about the transferor's identification (or to indicate "no identification" in the case of a transferor entity that may not have identification).		
<fc2:OtherIssuerCountryText/>	Record this element when a foreign identification is recorded.	Value must be the ISO-3166 2-char code associated with the	Item 78. Issuing jurisdiction (if foreign)

Element	Element Restrictions	Value Restrictions	Item #
		country/jurisdiction that issued the foreign identification.	
<fc2:PartyIdentificationNumberText/>	<p>For a transferor individual, this element must be recorded.</p> <p>For a transferor entity, record this element unless "No identification" is indicated.</p>	If SSN-ITIN or EIN, then value must be 9 numeric characters; otherwise, a foreign identification number can contain alpha and numeric characters up to 25 characters. The value cannot be "0" or all zeros.	Item 77. Identification number
<fc2:PartyIdentificationTypeCode/>	This element must be recorded.	<p>Value must be one of the following codes in parentheses (indicate one):</p> <p>If IRS-TIN, then: (1) SSN-ITIN or (2) EIN</p> <p>If no IRS-TIN, then: (43) Foreign taxpayer identification number</p> <p>If no foreign taxpayer identification number, then: For transferor entity: (41) Foreign entity registration number; For transferor individual (40) Foreign passport</p> <p>For transferor entity with no identification, then: (42) No identification</p>	Item 76. Identification type or "No identification"
</fc2:PartyIdentification>	Closing tag for identification.		
</fc2:Party>	Closing tag for Transferor [Individual or Entity].		

3.5.3.2. If Transferor is a Trust

If the transferor party type is a *trust*, the party will include the elements from the table below. Please note the following items and corresponding elements that are not included in the table below because they are not applicable to a transferee *trust*:

- Item 61: Transferor type – Entity: TransferPartyEntityIndicator
- Item 64: Alternate name: PartyName (a 2nd occurrence after legal name)
- Item 69: Foreign principal place of business with no U.S. location (indicator): ForeignPrincipalPlaceofBusinessWithNoUSLocationIndicator
- Items 65-67: First name (RawIndividualFirstName), middle name (RawIndividualMiddleName), and suffix (RawIndividualNameSuffixText)
- Item 68: Date of birth (IndividualBirthDateText)
- Items 70-75: Address (principal place of business): Address (and associated sub-elements)
- Item 76: Identification type – “Foreign passport” selection (PartyIdentificationTypeCode=40) and “Foreign entity registration number” (PartyIdentificationTypeCode=41) as these identification types are not applicable to a trust.

Element	Element Restrictions	Value Restrictions	Item #
<fc2:Party SeqNum="#">	This element must be recorded at least once per RER. This element is the container for information about a transferor that is a trust.		
<fc2:ActivityPartyTypeCode/>	This element must be recorded.	Value must be "69" to label this party as the transferor.	XML
<fc2:TransferPartyTrustIndicator/>	This element must be recorded.	Value must be "Y" to indicate the type of transferor as a trust.	Item 61. Transferor type (Trust)
<fc2:TrustInstrumentExecutionDateText/>	This element must be recorded.	Value must be in the format YYYYMMDD where YYYY=year (e.g. 2012). MM=month (01-12), and DD=day (01-31). Must be a valid date (e.g. 19990231 is invalid because there are not 31 days in February). Cannot be a future date.	Item 62. Date trust instrument executed
<fc2:PartyName SeqNum="#">	This element must be recorded once per transferor. This element is the container for information about the transferor's legal name.		
<fc2:PartyNameTypeCode/>	This element must be recorded.	Value must be "L" to associate the name with the transferor's	XML

Element	Element Restrictions	Value Restrictions	Item #
		legal name.	
<fc2:RawEntityIndividualLastName/>	This element must be recorded.	Value must be 150 characters or less.	Item 63. Last name or entity legal name
</fc2:PartyName>	Closing tag for legal name.		
<fc2:PartyIdentification SeqNum="#">	This element must be recorded once per transferor. This element is the container for information about the transferor's identification (or to indicate "no identification" in the case of a transferor trust that may not have identification).		
<fc2:OtherIssuerCountryText/>	Record this element when a foreign identification is recorded.	Value must be the ISO-3166 2-char code associated with the country/jurisdiction that issued the foreign identification.	Item 78. Issuing jurisdiction (if foreign)
<fc2:PartyIdentificationNumberText/>	Record this element unless "No identification" is indicated.	If SSN-ITIN or EIN, then value must be 9 numeric characters; otherwise, a foreign identification number can contain alpha and numeric characters up to 25 characters. The value cannot be "0" or all zeros.	Item 77. Identification number
<fc2:PartyIdentificationTypeCode/>	This element must be recorded for the transferor identification type (or to indicate "no identification" if the transferor trust does not have any identification).	Value must be one of the following codes in parentheses (indicate one): If IRS-TIN, then: (1) SSN-ITIN or (2) EIN If no IRS-TIN, then: (43) Foreign taxpayer identification number For transferor trust with no identification, then: (42) No identification	Item 76. Identification type or "No identification"

Element	Element Restrictions	Value Restrictions	Item #
</fc2:PartyIdentification>	Closing tag for identification.		
<fc2:PartyAssociation SeqNum="#">...</fc2:PartyAssociation/>	<p>This element must be recorded <u>at least once</u> per <i>transferor trust</i> in the RER. This element is the container for information about the associated trustee (individual or entity) recorded in Part IV of the RER. This element must be recorded separately for each associated trustee.</p> <p>For details about this element, see Party: Trustee Association with the Transferor Trust (individual or Entity)</p>		
</fc2:Party>	Closing tag for Transferor Trust.		

3.5.3.2.1. Party: Trustee Association with the Transferor Trust (individual or Entity)

Hierarchy: EFilingBatchXML / Activity / Party / PartyAssociation / Party

This is the trustee (*individual* or *entity*) recorded in Part IV (items 79-94) of the RER. The trustee party must be recorded at least once per transferee trust in the RER. If the associated transferee is NOT a trust, then the trustee party must NOT be recorded.

Element	Element Restrictions	Value Restrictions	Item #
<fc2:PartyAssociation SeqNum="#">	Record this element separately for each trustee associated with the transferor trust. This element is the container for information about the trustee associated with the transferor trust. The types of trustees that may be recorded are as follows: Trustee Individual or Trustee Entity. A trustee may only be recorded when the associated transferor is a trust (do not record a trustee if the associated transferor is an individual or an entity). The elements/items recorded for the trustee will depend on which type is being recorded (individual or entity).		
<fc2:Party SeqNum="#">	This element must be recorded once per PartyAssociation element. This element is the container for information about the trustee associated with the transferor trust.		
<fc2:ActivityPartyTypeCode/>	This element must be recorded.	Value must be "70" to label this party as the trustee associated with the transferor trust.	XML
<fc2:ForeignPrincipalPlaceofBusinessWithNoUSLocationIndicator/>	Record this element when the trustee is an entity that has a foreign principal place of business with no U.S. location.	Value must be "Y" or null. If recorded with a "Y" value, then only one address (i.e. the foreign principal place of business) shall be recorded for the trustee entity.	Item 85. Foreign principal place of business with no U.S. location
<fc2:PartyAsEntityOrganizationIndicator/>	Record this element when the trustee is an entity.	Value must be "Y" or null.	Item 80. If entity
<fc2:PartyName SeqNum="#">	This element must be recorded for the trustee regardless of type. This element is the container for information about the trustee's legal name.		
<fc2:PartyNameTypeCode/>	This element must be recorded.	Value must be "L" to associate the name with the trustee's legal name.	XML

Element	Element Restrictions	Value Restrictions	Item #
<fc2:RawEntityIndividualLastName/>	This element must be recorded.	Value must be 150 characters or less.	Item 79. Last name or entity legal name
<fc2:RawIndividualFirstName/>	Record this element when the trustee is an individual.	Value must be 35 characters or less.	Item 82. First name
<fc2:RawIndividualMiddleName/>	Record this element when the trustee is an individual and they have a middle name.	Value must be 35 characters or less.	Item 83. Middle name
<fc2:RawIndividualNameSuffixText/>	Record this element when the trustee is an individual and they have a suffix name.	Value must be 35 characters or less.	Item 84. Suffix
</fc2:PartyName>	Closing tag for legal name.		
<fc2:PartyName SeqNum="#">	Record this element when the trustee is an entity and the entity has an alternate name. Do not record this element if the trustee entity does not have an alternate name or if the trustee is an individual.		
<fc2:PartyNameTypeCode/>	This element must be recorded if the parent element is recorded.	Value must be "DBA" to associate the name with the trustee entity's alternate name.	XML
<fc2:RawPartyFullName/>	This element must be recorded if the parent element is recorded.	Value must be 150 characters or less.	Item 81. Alternate name
</fc2:PartyName>	Closing tag for alternate name.		
<fc2:Address SeqNum="#">	This element must be recorded for the trustee regardless of type. If the trustee is an entity, then this element is the container for the address associated with the entity's principal place of business. If the trustee is an individual, then this element is the container for the individual's residential address.		
<fc2:RawCityText/>	This element must be recorded.	Value must be 50 characters or less	Item 88. City

Element	Element Restrictions	Value Restrictions	Item #
<fc2:RawCountryCodeText/>	This element must be recorded.	Value must be ISO-3166 2-char country/jurisdiction code. If U.S. Territory, record the ISO-3166 2-char code associated with a U.S. Territory and record the same U.S. Territory code for the State/U.S. Territory field.	Item 89. Country/Jurisdiction
<fc2:RawStateCodeText/>	Record this element when the associated country/jurisdiction is the United States, a U.S. Territory, Canada, or Mexico.	Value must be ISO-3166 code. If the address is in the United States, then record the 2-char U.S. state code. If the address is in a U.S. Territory, the same ISO-3166 2-character territory code recorded for the country must also be recorded here. If the address is in Canada, record the 2-char Canadian state/province/territory code. If the address is in Mexico, record the 3-char Mexican state/province/territory code. If the address is in a foreign country/jurisdiction other than Canada or Mexico, do not record this element.	Item 90. State/U.S. Territory
<fc2:RawStreetAddress1Text/>	This element must be recorded.	Value must be 100 characters or less	Item 87. Street address (number, street, and apt. or suite no.)
<fc2:RawZIPCode/>	Record this element when the associated country/jurisdiction is the United States, a U.S. Territory, Canada, or Mexico. If the associated country/jurisdiction is none of the above, the element need not	Value must be a valid numeric entry equal to 5 or 9 digits if the associated country/jurisdiction is United States or a U.S. Territory. If the associated country/jurisdiction is foreign, then the value may contain alpha	Item 90. ZIP/Foreign postal code

Element	Element Restrictions	Value Restrictions	Item #
	be recorded if a foreign postal code is not applicable.	and numeric up to 9-characters. In either scenario, do not enter "0", all zeros, or 5-digits followed by 4-zeros (e.g. 552140000).	
<fc2:ValueTransferAddressTypeCode/>	Record this element when the trustee is an entity.	Value must be one of the following codes in parentheses (indicate one): (1) Principal place of business (U.S.) (2) Foreign principal place of business (non-U.S.)	Item 86. Address type
</fc2:Address>	Closing tag for address (principal place of business).		
<fc2:Address SeqNum="#">	Record this element when the trustee is an entity and the entity has a primary U.S. location where it conducts business in addition to their foreign principal place of business. This element is the container for the address associated with the entity's primary U.S. location where it conducts business. If the trustee entity's principal place of business is in the United States, or if the principal place of business is foreign and it does not have a primary U.S. location where it conducts business, then do not record this element. Do not record this element if the trustee is an individual.		
<fc2:RawCityText/>	This element must be recorded if the parent element is recorded.	Value must be 50 characters or less	Item 88. City
<fc2:RawCountryCodeText/>	This element must be recorded if the parent element is recorded.	Value must be "US" (if United States) or the ISO-3166 2-character code associated with a U.S. Territory.	Item 89. Country/Jurisdiction
<fc2:RawStateCodeText/>	This element must be recorded if the parent element is recorded.	Value must be ISO-3166 2-character U.S. state code, or if in a U.S. Territory, the same ISO-3166 2-character territory code recorded for the country must also be recorded here.	Item 90. State/U.S. Territory

Element	Element Restrictions	Value Restrictions	Item #
<fc2:RawStreetAddress1Text/>	This element must be recorded if the parent element is recorded.	Value must be 100 characters or less	Item 87. Street address (number, street, and apt. or suite no.)
<fc2:RawZIPCode/>	This element must be recorded if the parent element is recorded.	Value must be a valid numeric entry equal to 5 or 9 digits; do not enter "0", all zeros, or 5-digits followed by 4-zeros (e.g. 552140000).	Item 90. ZIP/Foreign postal code
<fc2:ValueTransferAddressTypeCode/>	This element must be recorded if the parent element is recorded.	Value must be "3" to indicate "Primary U.S. location where entity conducts business."	Item 86. Address type
</fc2:Address>	Closing tag for address (primary U.S. location).		
<fc2:PartyIdentification SeqNum="#">	This element must be recorded once per trustee. This element is the container for information about the trustee identification (or to indicate "no identification" in the case of a trustee entity that may not have identification).		
<fc2:OtherIssuerCountryText/>	Record this element when a foreign identification is recorded.	Value must be the ISO-3166 2-char code associated with the country/jurisdiction that issued the foreign identification.	Item 94. Issuing jurisdiction (if foreign)
<fc2:PartyIdentificationNumberText/>	Record this element unless "No identification" is indicated (for a trustee entity only)	If SSN-ITIN or EIN, then value must be 9 numeric characters; otherwise, a foreign identification number can contain alpha and numeric characters up to 25 characters. The value cannot be "0" or all zeros.	Item 93. Identification number
<fc2:PartyIdentificationTypeCode/>	This element must be recorded for the trustee identification type (or to indicate "no identification"	Value must be one of the following codes in parentheses (indicate one):	Item 92. Identification type or "No identification"

Element	Element Restrictions	Value Restrictions	Item #
	if the trustee is an entity and does not have any identification).	If IRS-TIN, then: (1) SSN-ITIN or (2) EIN If no IRS-TIN, then: (43) Foreign taxpayer identification number If no foreign taxpayer identification number, then: For trustee entity: (41) Foreign entity registration number; For trustee individual (40) Foreign passport For trustee entity with no identification, then: (42) No identification	
</fc2:PartyIdentification>	Closing tag for identification.		
</fc2:Party>	Closing tag for Trustee.		
</fc2:PartyAssociation>	Closing tag for Trustee Association to Transferor Trust.		

3.5.4. Administrative Data

In addition to the Activity level party types associated with each RER, the following party types are recorded (also at the Activity level) for administrative purposes. This information is needed to identify the individual point of contact and associated organization who creates the RER batch in XML format for the reporting person.

3.5.4.1. Party: Transmitter

Hierarchy: [EFilingBatchXML](#) / [Activity](#) / [Party](#)

This is the organization that creates the RER batch XML, either on its own behalf, or on behalf of the reporting person. If the reporting person has designated a third-party service provider to generate the RER batch data on the reporting person's behalf, information about the third-party service provider should be recorded as the Transmitter. This party type must be recorded once per RER in the batch and should be identical for each RER in the batch.

Element	Element Restrictions	Value Restrictions	Item #
<Party SeqNum="#">	This element must be recorded once per RER. This element is the container for information about transmitter of the batch.		
<fc2:ActivityPartyTypeCode/>	This element must be recorded.	Value must be "35" to label this party as the transmitter.	XML
<fc2:PartyName SeqNum="#">	This element must be recorded once per transmitter. This element is the container for information about transmitter's legal name.		
<fc2:PartyNameTypeCode/>	This element must be recorded.	Value must be "L" to associate the name with the transmitter's legal name.	XML
<fc2:RawPartyFullName/>	This element must be recorded.	Value must be 150 characters or less.	XML
</fc2:PartyName>	Closing tag for legal name.		
<fc2:Address SeqNum="#">	This element must be recorded once per transmitter. This element is the container for information about transmitter's address.		
<fc2:RawCityText/>	This element must be recorded.	Value must be 50 characters or less	XML

Element	Element Restrictions	Value Restrictions	Item #
<fc2:RawCountryCodeText/>	This element must be recorded if the parent element is recorded.	Value must be ISO-3166 2-char country/jurisdiction code. If U.S. Territory, record the ISO-3166 2-char code associated with a U.S. Territory and record the same U.S. Territory code for the State/U.S. Territory field.	
<fc2:RawStateCodeText/>	Record this element when the associated country/jurisdiction is the United States, a U.S. Territory, Canada, or Mexico.	Value must be ISO-3166 code. If the address is in the United States, then record the 2-char U.S. state code. If the address is in a U.S. Territory, the same ISO-3166 2-character territory code recorded for the country must also be recorded here. If the address is in Canada, record the 2-char Canadian state/province/territory code. If the address is in Mexico, record the 3-char Mexican state/province/territory code. If the address is in a foreign country/jurisdiction other than Canada or Mexico, do not record this element.	XML
<fc2:RawStreetAddress1Text/>	This element must be recorded.	Value must be 100 characters or less	XML
<fc2:RawZIPCode/>	Record this element when the associated country/jurisdiction is the United States, a U.S. Territory, Canada, or Mexico. If the associated country/jurisdiction is none of the above, the element need not be recorded if a foreign postal code is not applicable.	Value must be a valid numeric entry equal to 5 or 9 digits if the associated country/jurisdiction is United States or a U.S. Territory. If the associated country/jurisdiction is foreign, then the value may contain alpha and numeric up to 9-characters. In either scenario, do not enter "0", all zeros, or 5-digits followed by 4-zeros (e.g. 552140000).	XML
</fc2:Address>	Closing tag for address.		

Element	Element Restrictions	Value Restrictions	Item #
<fc2:PhoneNumber SeqNum="#">	This element must be recorded once per transmitter. This element is the container for information about transmitter's telephone number.		
<fc2:PhoneNumberText/>	This element must be recorded.	Value must be 16 numeric characters or less.	XML
</fc2:PhoneNumber>	Closing tag for phone number.		
<fc2:PartyIdentification SeqNum="#">	This element must be recorded twice per transmitter. This is the first instance of this element, which contains information about transmitter's taxpayer identification number (TIN).		
<fc2:PartyIdentificationNumberText/>	This element must be recorded.	For an IRS-Issue taxpayer identification number, the value must be 9 numeric characters; otherwise, a foreign taxpayer identification number can contain alpha and numeric characters up to 25 characters. The value cannot be "0" or all zeros.	XML
<fc2:PartyIdentificationTypeCode/>	This element must be recorded.	Value must be "4" to label as the taxpayer identification number.	XML
</fc2:PartyIdentification>	Closing tag for Taxpayer Identification Number (TIN).		
<fc2:PartyIdentification SeqNum="#">	This element must be recorded twice per transmitter. This is the second instance of this element, which contains the transmitter control code (TCC). A test TCC is issued to the transmitter (by FinCEN) for use during testing. Then, upon a thorough and successful testing effort by the transmitter, FinCEN issues a production TCC.		
<fc2:PartyIdentificationNumberText/>	This element must be recorded.	Value must be "TBSATEST" when testing in FinCEN's sandbox environment (https://bsaefiling-sandbox.fincen.gov). To request the production TCC, please submit a ticket at https://bsaefiling.fincen.gov/HelpTicketForm once you have successfully complete testing.	XML

Element	Element Restrictions	Value Restrictions	Item #
<fc2:PartyIdentificationTypeCode/>	This element must be recorded.	Value must be "28" to label as the Transaction Control Code.	XML
</fc2:PartyIdentification>	Closing tag for Transmitter Control Code (TCC).		
</fc2:Party>	Closing tag for Transmitter.		

3.5.4.2. Party: Transmitter Contact

Hierarchy: [EFilingBatchXML](#) / [Activity](#) / [Party](#)

This is the name of the point of contact for the transmitter described above. The transmitter contact party type must be recorded once per RER in the batch.

Element	Element Restrictions	Value Restrictions	Item #
<Party SeqNum="#">	This element must be recorded once per RER. This element is the container for information about transmitter point of contact.		
<fc2:ActivityPartyTypeCode/>	This element must be recorded.	Value must be "37" to label this party as the transmitter contact.	XML
<fc2:PartyName SeqNum="#">	This element must be recorded once per transmitter contact. This element is the container for information about transmitter contact's legal name.		
<fc2:PartyNameTypeCode/>	This element must be recorded.	Value must be "L" to associate the name with the transmitter contact person's legal name.	XML
<fc2:RawPartyFullName/>	This element must be recorded.	Value must be 150 characters or less.	XML
</fc2:PartyName>	Closing tag for legal name.		
</fc2:Party>	Closing tag for Transmitter Contact.		

3.6. AssetsAttribute (Property Address and Legal Description)

Hierarchy: [EFilingBatchXML](#) / [Activity](#) / [AssetsAttribute](#)

The AssetsAttribute element is the container for information about the property recorded in Part II (Items 16-22) of the RER. The AssetsAttribute element must be recorded at least once per RER. The AssetsAttribute element includes the following:

Element	Element Restrictions	Value Restrictions	Item #
<fc2:AssetsAttribute SeqNum="#">	This element must be recorded at least once per RER. This element is the container for information about the property involved in the reportable transfer. If multiple properties are involved in the reportable transfer, this element must be recorded separately for each property (i.e. one per property).		
<fc2:LegalDescriptionText/>	This element must be recorded.	Value must be 1000 characters or less	Item 22. Legal description (Enter the legal description of the property verbatim from the relevant deed in its entirety or the first 1000 characters)
<fc2:LegalDescriptionTypeCode/>	This element must be recorded.	Value must be one of the following codes in parentheses (indicate one): (1) Lot and block; (2) Subdivision; (3) Metes and bounds; (999) Other	Item 21. Legal description type
<fc2:OtherLegalDescriptionTypeDescriptionText/>	Record this element if "Other" is indicated for the legal description type.	Value must be 50 characters or less	Item 21. Legal description type - Other description
<fc2:RawCityText/>	This element must be recorded.	Value must be 50 characters or less	Item 17. City
<fc2:RawCountryCodeText/>	This element must be recorded.	Value must be "US" (if United States) or the ISO-3166 2-character code associated with a U.S. Territory.	Item 18. U.S./U.S. Territory
<fc2:RawStateCodeText/>	This element must be recorded.	Value must be ISO-3166 2-character U.S. state code, or if in a U.S. Territory, the same ISO-3166 2-character territory code	Item 19. State/U.S. Territory

Element	Element Restrictions	Value Restrictions	Item #
		recorded for the country must also be recorded here.	
<fc2:RawStreetAddress1Text/>	This element must be recorded unless "No street address" is indicated.	Value must be 100 characters or less	Item 16. Street address (number, street, and apt. or suite no.)
<fc2:RawZIPCode/>	This element must be recorded.	Value must be a valid numeric entry equal to 5 or 9 digits; do not enter "0", all zeros, or 5-digits followed by 4-zeros (e.g. 552140000).	Item 20. ZIP code
<fc2:StreetAddressNoneIndicator/>	Record this element if there is no street address associated with the property.	Value must be "Y" or null.	Item 16a. No street address
</fc2:AssetsAttribute>	Closing tag for Property.		

3.7. ValueTransferActivity (Payment Information)

Hierarchy: [EFilingBatchXML](#) / [Activity](#) / [ValueTransferActivity](#)

The ValueTransferActivity element is the container for information about the payment(s) recorded in Part V (Items 95-97 as well as Items 98-111 for each payment made by or on behalf of the Transferee) of the RER. The ValueTransferActivity element must be recorded once per RER in the batch XML; however, if multiple payments are associated with the RER, each payment is recorded in a separate [ValueTransferActivityDetail](#) container sub-element. The ValueTransferActivity container element includes the following elements:

Element	Element Restrictions	Value Restrictions	Item #
<fc2:ValueTransferActivity SeqNum="#">	This element must be recorded once per RER. This element is the container for information about the payment(s) involved in the reportable transfer.		
<fc2:MoneyOtherLoanIndicator/>	Record this element to indicate that hard money, private, or other similar loans are involved in the reportable transfer	Value must be "Y" or null.	Item 96. Hard money, private, or other similar loans involved in reportable transfer
<fc2:MoneyOtherLoanTypeCode/>	Record this element to indicate the type of hard money, private, or other similar loans involved in the reportable transfer	Value must be one of the following codes in parentheses (indicate one): (1) Hard money loan; (2) Private loan; (3) Seller financed loan; (999) Other	Item 97. Type of hard money, private, and other similar loans
<fc2:NoConsiderationPaidIndicator/>	Record this element when there is no consideration paid or to be paid, regarding the reportable transfer as a whole.	Value must be "Y" or null.	Item 95(a). No consideration paid
<fc2:OtherMoneyOtherLoanTypeCodeText/>	Record this element if "Other" is indicated for the hard money (or other similar loan) type.	Value must be 50 characters or less	Item 97. Type of hard money, private, and other similar loans - Other description
<fc2:TotalConsiderationPaidAmountText/>	Record this element unless "no consideration paid" is indicated.	Value must be 15 digits or less. Enter amount in whole U.S. dollars greater than 0. Example: \$98,015.26 should be rounded up	Item 95. Total consideration paid (in U.S. dollars)

Element	Element Restrictions	Value Restrictions	Item #
		to the next whole dollar and recorded as "98016".	
<fc2:TransactionClosingDateText/>	This element must be recorded.	Value must be in the format YYYYMMDD where YYYY=year (e.g. 2026). MM=month (01-12), and DD=day (01-31). Must be a valid date (e.g. 20260231 is invalid because there are not 31 days in February). Cannot be a future date.	Item 15. Date of closing
<fc2:ValueTransferActivityDetail SeqNum="#">...</fc2:ValueTransferActivityDetail>	<p>This element must be recorded at least once per RER. This element is the container for information about the payment involved in the reportable transfer. If multiple payments are involved in the reportable transfer, this element must be recorded separately for each payment (i.e. one per payment). If "no consideration paid" is indicated for the transfer as a whole, then there will be no payments to record in the RER and, therefore, this element would not be recorded for the RER.</p> <p>For details about this element, see ValueTransferActivityDetail</p>		
</fc2:ValueTransferActivity>	Closing tag for Payment.		

3.7.1. ValueTransferActivityDetail (Payment(s) made by or on behalf of Transferee(s))

Hierarchy: [EFilingBatchXML](#) / [Activity](#) / [ValueTransferActivity](#) / [ValueTransferActivityDetail](#)

The ValueTransferActivityDetail element is the container for information about each payment recorded in Part V (Items 98-111) of the RER. If “No consideration paid” is indicated for the RER in Item 95 (Total consideration paid), then no payment information shall be recorded in Items 98-111 – and as a result, no ValueTransferActivityDetail element shall be recorded for the RER. Otherwise, the ValueTransferActivityDetail container element shall be recorded once per payment in the RER. The ValueTransferActivityDetail container element includes the following elements:

Element	Element Restrictions	Value Restrictions	Item #
<fc2:ValueTransferActivityDetail SeqNum="#">	This element must be recorded at least once per RER. This element is the container for information about each payment involved in the reportable transfer. If multiple payments are involved in the reportable transfer, this element must be recorded separately for each payment (i.e. one per payment). If "no consideration paid" is indicated for the transfer as a whole, then there will be no payments to record in the RER and this element would not be recorded for the RER.		
<fc2:AllPayorsAreRecordedTransfereesIndicator/>	Record this element to indicate that all payors are all recorded transferees in Part III or all recorded transferees in field/item 105.	Value must be "Y" or null.	Item 106. All payors are all recorded transferees in Part III or all recorded transferees in field 105
<fc2:ForeignCurrencyTypeCodeText/>	Record this element to identify the currency code when a foreign currency is involved in the payment.	Value must be ISO-4217 3-char currency code, or "999" to indicate "Other" in the event that the foreign currency associated with this payment is not listed in the ISO-4217 list.	Item 100. If foreign payment method, select currency code
<fc2:OtherForeignCurrencyTypeCodeText/>	Record this element if "Other" is indicated for the foreign currency code.	Value must be 50 characters or less	Item 100. If foreign payment method, select currency code - Other description
<fc2:PaymentAmountText/>	This element must be recorded (when the parent element is recorded).	Value must be 15 digits or less. Enter amount in whole U.S. dollars greater than 0. Example: \$98,015.26 should be rounded up to the next whole dollar and	Item 98. Payment amount (in U.S. dollars)

Element	Element Restrictions	Value Restrictions	Item #
		recorded as "98016".	
<fc2:PaymentAssociatedWithAllTransfereesIndicator/>	Record this element to indicate that the payment is associated with all transferees recorded in Part III.	Value must be "Y" or null.	Item 104. Payment associated with all recorded transferees in Part III
<fc2:PaymentNotFromFinancialInstitutionAccountIndicator/>	Record this element to indicate that the payment is not from a financial institution account.	Value must be "Y" or null.	Item 101. Payment is not from a financial institution account
<fc2:Assets SeqNum="#">...</fc2:Assets>	<p>This container element must be recorded once per payment (ValueTransferActivityDetail) recorded in the RER.</p> <p>For details about this element, see Assets.</p>		
<fc2:Party SeqNum="#">...</fc2:Party>	<p>Associated financial institution where the account is held (if any). Record this party when the payment involves an account held at a financial institution; otherwise, indicate in Item 101 (PaymentNotFromFinancialInstitutionAccountIndicator=Y) that the "payment is NOT from a financial institution account" and do NOT record this party. Only one of this party type can be recorded for each ValueTransferActivityDetail on the RER.</p> <p>For details about this element, see Party: Financial Institution (FI) where account is held</p>		
<fc2:Party SeqNum="#">...</fc2:Party>	<p>Associated transferee (if any). Record this party for each transferee recorded in Part III that the payment is associated with; however, if the payment is associated with all recorded transferees in Part III, indicate as such in Item 104 (PaymentAssociatedWithAllTransfereesIndicator=Y) and do NOT record this party. Multiples of this party type can be recorded for each ValueTransferActivityDetail on the RER.</p> <p>For details about this element, see Party: Transferee associated with the Payment</p>		
<fc2:Party SeqNum="#">...</fc2:Party>	<p>Associated payor (if any). Record this party for each payor recorded in Part III (Items 107-111) that the payment is associated with; however, if all payors are all recorded transferees in Part III or all recorded transferees in field 105, indicate as such in item 106 (AllPayorsAreRecordedTransfereesIndicator=Y) and do NOT record this party. Multiples of this party type can be recorded for each ValueTransferActivityDetail on the RER.</p> <p>For details about this element, see Party: Payor associated with the Payment</p>		

Element	Element Restrictions	Value Restrictions	Item #
</fc2:ValueTransferActivityDetail>	Closing tag for Payment Details.		

3.7.1.1. Assets (Payment Method)

Hierarchy: [EFilingBatchXML](#) / [Activity](#) / [ValueTransferActivity](#) / [ValueTransferActivityDetail](#) / **Assets**

The Assets element is the container for information about the payment method (Item 99) for the associated payment (Items 98-111) recorded in Part V of the RER. The Assets element must be recorded once per payment in the RER. The Assets container element includes the following elements:

Element	Element Restrictions	Value Restrictions	Item #
<fc2:Assets SeqNum="#">	This container element must be recorded once per payment (ValueTransferActivityDetail) recorded in the RER.		
<fc2:AssetSubtypeID/>	This element must be recorded (when the parent element is recorded).	Value must be one of the following codes in parentheses (indicate one): (48) Wire (49) Cashier's check (37) Personal/Business check (36) Money order (39) U.S. currency (32) Foreign currency (50) Digital assets (51) Stocks/Bonds (41) Other	Item 99. Payment method
<fc2:OtherAssetSubtypeText/>	Record this element if "Other" is indicated for the payment method	Value must be 50 characters or less	Item 99. Payment method - Other description
</fc2:Assets>	Closing tag for Payment method.		

3.7.1.2. Party

3.7.1.2.1. Party: Financial Institution (FI) where account held

*Hierarchy: [EFilingBatchXML](#) / [Activity](#) / [ValueTransferActivity](#) / [ValueTransferActivityDetail](#) / **Party***

In the event that an account (held at a financial institution) is involved in the payment, this party type is the container for information about the financial institution (specifically, the legal name of the financial institution); however, if item 101 “Payment is not from a financial institution account” is indicated, then this party type (along with the account number information) shall not be recorded for the payment.

Element	Element Restrictions	Value Restrictions	Item #
<fc2:Party SeqNum="#">	Associated financial institution where the account is held (if any). Record this party when the payment involves an account held at a financial institution; otherwise, indicate in Item 101 (PaymentNotFromFinancialInstitutionAccountIndicator =Y) that the “payment is NOT from a financial institution account” and do NOT record this party. Only one of this party type can be recorded for each ValueTransferActivityDetail on the RER.		
<fc2:ActivityPartyTypeCode/>	This element must be recorded if the parent element is recorded.	Value must be "41" to label this party as the financial institution in which account is held.	XML
<fc2:PartyName SeqNum="#">	This element must be recorded if the parent element is recorded. This element is the container for the name of the financial institution where the account is held.		
<fc2:PartyNameTypeCode/>	This element must be recorded if the parent element is recorded.	Value must be "L" to associate the name with the financial institution's (where the account is held) legal name.	XML
<fc2:RawPartyFullName/>	This element must be recorded if the parent element is recorded.	Value must be 150 characters or less.	Item 103. Financial institution legal name
</fc2:PartyName>	Closing tag for legal name.		
<fc2:Account SeqNum="#">	This element must be recorded if the parent element is recorded. This element is the container for the account number associated with the payment.		

Element	Element Restrictions	Value Restrictions	Item #
<fc2:AccountNumberText/>	This element must be recorded if the parent element is recorded.	Value must be 40 characters or less. Value must be entered as a single alpha/numeric text string without formatting or special characters.	Item 102. Account number
</fc2:Account>	Closing tag for Account.		
</fc2:Party>	Closing tag for Financial Institution.		

3.7.1.2.2. Party: Transferee associated with the Payment

Hierarchy: [EFilingBatchXML](#) / [Activity](#) / [ValueTransferActivity](#) / [ValueTransferActivityDetail](#) / **Party**

This party type is the container for the name (item 105) of the recorded transferee that is associated with the payment. The associated transferee party type can be recorded multiple times per payment depending on the number of recorded transferees associated with the payment; however, if item 104 “Payment associated with all recorded transferees in Part III” is indicated, then this party type need shall not be recorded for the payment.

Element	Element Restrictions	Value Restrictions	Item #
<fc2:Party SeqNum="#">	Associated transferee (if any). Record this party for each transferee recorded in Part III that the payment is associated with; however, if the payment is associated with all recorded transferees in Part III, indicate as such in Item 104 (PaymentAssociatedWithAllTransfereesIndicator=Y) and do NOT record this party. Multiples of this party type can be recorded for each ValueTransferActivityDetail on the RER.		
<fc2:ActivityPartyTypeCode/>	This element must be recorded if the parent element is recorded.	Value must be "71" to label this party as the transferee associated with this payment.	XML
<fc2:PartyName SeqNum="#">	This element must be recorded if the parent element is recorded. This element is the container for the name of the transferee recorded in Part III that is associated with this payment.		
<fc2:PartyNameTypeCode/>	This element must be recorded if the parent element is recorded.	Value must be "L" to associate the name with the associated transferee's legal name.	XML
<fc2:RawPartyFullName/>	This element must be recorded if the parent element is recorded.	Value must be 150 characters or less.	Item 105. Associated transferee legal name
</fc2:PartyName>	Closing tag for legal name.		
</fc2:Party>	Closing tag for Transferee associated with payment.		

3.7.1.2.3. Party: Payor associated with the Payment

Hierarchy: [EFilingBatchXML](#) / [Activity](#) / [ValueTransferActivity](#) / [ValueTransferActivityDetail](#) / **Party**

This party type is the container for the name (items 107-111) of the payor associated with the payment. The payor party type can be recorded multiples times per payment depending on the number of payors associated with the payment; however, if Item 106 "All payors are all recorded transferees in Part III or all recorded transferees in Item 105" is indicated, then this party type shall not be recorded for the payment.

Element	Element Restrictions	Value Restrictions	Item #
<fc2:Party SeqNum="#">	Associated payor (if any). Record this party for each payor recorded in Part III (Items 107-111) that the payment is associated with; however, if all payors are all recorded transferees in Part III or all recorded transferees in field 105, indicate as such in item 106 (AllPayorsAreRecordedTransfereesIndicator=Y) and do NOT record this party. Multiples of this party type can be recorded for each ValueTransferActivityDetail on the RER.		
<fc2:ActivityPartyTypeCode/>	This element must be recorded.	Value must be "72" to label this party as the payor associated with this payment.	XML
<fc2:PartyAsEntityOrganizationIndicator/>	Record this element when the payor is an entity.	Value must be "Y" or null.	Item 108. If entity
<fc2:PartyName SeqNum="#">	This element must be recorded. This element is the container for the name of the payor recorded in Part V that is associated with this payment.		
<fc2:PartyNameTypeCode/>	This element must be recorded.	Value must be "L" to associate the name with the payor's legal name.	XML
<fc2:RawEntityIndividualLastName/>	This element must be recorded.	Value must be 150 characters or less.	Item 107. Last name or entity legal name
<fc2:RawIndividualFirstName/>	Record this element when the payor is an individual.	Value must be 35 characters or less.	Item 109. First name
<fc2:RawIndividualMiddleName/>	Record this element when the payor is an individual and they have a middle name.	Value must be 35 characters or less.	Item 110. Middle name

Element	Element Restrictions	Value Restrictions	Item #
<fc2:RawIndividualNameSuffixText/>	Record this element when the payor is an individual and they have a suffix name.	Value must be 35 characters or less.	Item 111. Suffix
</fc2:PartyName>	Closing tag for legal name.		
</fc2:Party>	Closing tag for Payor.		

4. RER XML Batch Acknowledgement

The RER XML batch acknowledgement file defined below is provided in XML format. The acknowledgement file will contain a BSA Identifier (BSA ID) and any corresponding acknowledgement errors (if any) associated with each RER element received in the batch submission.

Please visit https://www.fincen.gov/system/files/schema/base/EFL_BatchAcknowledgementSchema.xsd to access the batch acknowledgement schema.

4.1. XML File Structure

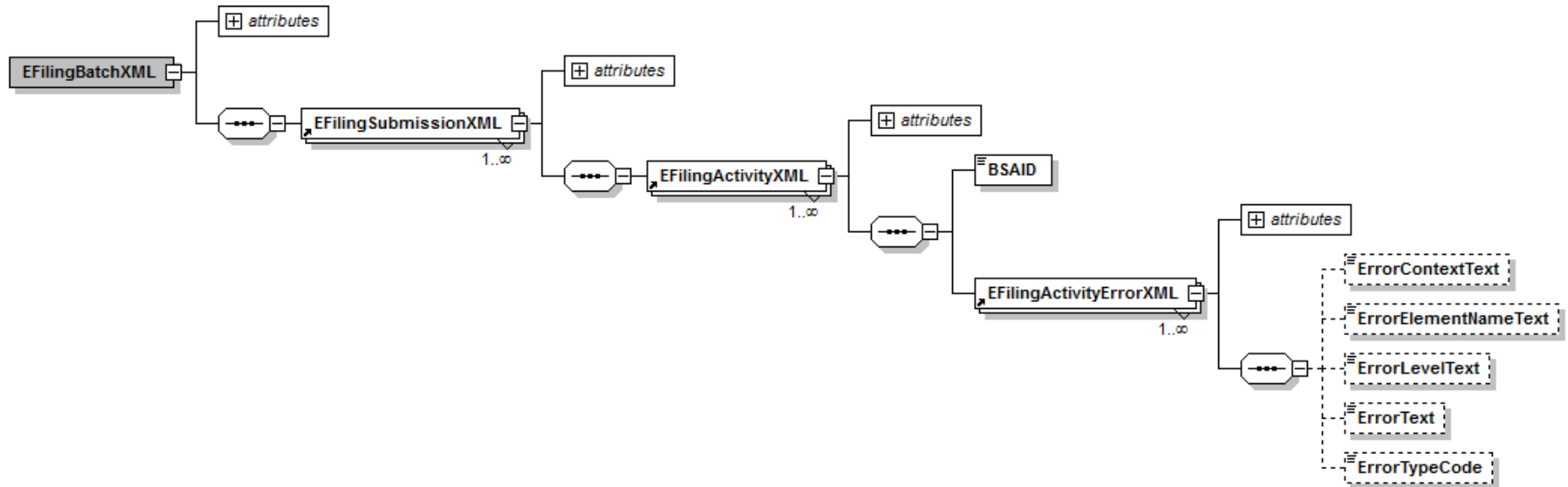

4.2. XML declaration (prolog)

The XML declaration (i.e. prolog) appears as the first line of the acknowledgement file:

```
<?xml version="1.0" encoding="UTF-8"?>
```

4.3. EFilingBatchXML

The **EFilingBatchXML** element is the first element recorded in the acknowledgement file as the root element.

Element	Element Restrictions	Value Restrictions	Item #
<?xml version="1.0" encoding="UTF-8"?>	Prolog. Will be recorded once at the beginning of the RER acknowledgement XML.		
<fc2:EFilingBatchXML ActivityCount="#" xmlns="www.fincen.gov/base" SeqNum="#" StatusCode="A">	Root. Will be recorded once in the RER acknowledgement XML. This element is the container for all RERs submissions being acknowledged in from the corresponding batch XML. It includes the following attributes:	<ul style="list-style-type: none"> xmlns="www.fincen.gov/base" SeqNum="#" (the "#" will be an assigned number by FinCEN for reference purposes only (e.g., SeqNum="186")) StatusCode="A" (A=Acknowledged) 	
<fc2:EFilingSubmissionXML SeqNum="1" StatusCode="A">...</fc2:EFilingSubmissionXML>	This element will be recorded once per RER acknowledgement XML This element is the container for each RER (one EFilingActivityXML element per Activity element in the corresponding RER batch XML) that has been acknowledged (and as a result, assigned a BSA Identifier) by FinCEN.		
</fc2:EFilingBatchXML>	Closing tag for the RER acknowledgment.		

4.4. EFilingSubmissionXML

The **EFilingSubmissionXML** element is the second element recorded in the acknowledgement file.

Element	Element Restrictions	Value Restrictions	Example
<code><fc2:EFilingSubmissionXML SeqNum="1" Status="A"></code>	<p>This element is recorded once per RER acknowledgement XML. This element is the container for each RER (one EFilingActivityXML element per Activity element in the corresponding RER batch XML) that has been acknowledged (and as a result, assigned a BSA Identifier) by FinCEN. This element will contain two attributes:</p> <ul style="list-style-type: none"> • SeqNum="1" (the value will always be "1") • Status="A" (A=Acknowledged. The value will always be "A") 		
<code><fc2:EFilingActivityXML SeqNum="#">...</fc2:EFilingActivityXML></code>	<p>This element is recorded once for each RER Activity in the corresponding batch XML.</p> <p>For details about this element, see EFilingActivityXML below.</p>		
<code></fc2:EFilingSubmissionXML></code>	<p>Closing tag for the EFilingSubmissionXML element.</p>		

4.5. EFilingActivityXML

The **EFilingActivityXML** element is the third element recorded in the acknowledgement file. The number of EFilingActivityXML elements recorded in the acknowledgement XML file equals the number of Activity elements recorded in the associated RER batch XML file.

Element	Element Restrictions	Value Restrictions	Example
<fc2:EFilingActivityXML SeqNum="#">	This element is recorded once for each RER Activity in the corresponding batch XML. This element will contain the following attribute: <ul style="list-style-type: none"> SeqNum="#" (the "#" will match the SeqNum from the corresponding RER batch XML. For example, if the first Activity recorded in your RER batch submission contained SeqNum value "12", then the first EFilingActivityXML recorded in the acknowledgement XML will have SeqNum value "12") 		
<fc2:BSAID/>	This element will always be recorded.	The value will always be a unique 14-digit number assigned by FinCEN to each RER in your batch.	<BSAID>31000999999999</BSAID>
<fc2:EFilingActivityErrorXML SeqNum="#">...</fc2:EFilingActivityErrorXML>	This element is recorded once for each RER Activity in the corresponding batch XML. For details about this element, see EFilingActivityErrorXML below.		
</fc2:EFilingActivityXML>	Closing tag for the EFilingActivityXML element.		

4.6. EFilingActivityErrorXML

The **EFilingActivityErrorXML** element is the container for each error associated with the EFilingActivityXML (i.e. each RER Activity recorded in the RER Batch XML file). The number of EFilingActivityErrorXML elements recorded in the acknowledgement XML file will be determined by the number of errors generated for each RER. If there are no errors returned for a given EFilingActivityXML (i.e. RER) in your acknowledgement XML, this element will be self-closing (i.e. <EFilingActivityErrorXML SeqNum="1"/>).

Element	Element Restrictions	Value Restrictions	Example
<fc2:EFilingActivityErrorXML SeqNum="#">	<p>This element is recorded once for each EFilingActivityXML in the RER acknowledgement XML. This element is the container for one or more errors generated for the associated RER Activity in the corresponding batch XML. If there are no errors generated for the associated RER, then this element will be recorded with a self-closing tag as such: <EFilingActivityErrorXML SeqNum="1"/></p> <p>This element will contain two attributes:</p> <ul style="list-style-type: none"> SeqNum="1" (the value will always begin with "1" for each RER (EFilingActivityXML) and increase by 1 for each error recorded for the associated RER) 		
<fc2:ErrorContextText/>	This element identifies the element location (within the associated batch submission) that triggered the error. This element identifies the name and sequence number (in brackets) of the associated element's <i>parent</i> element from the batch submission.	The value can be up to 4000 characters.	<fc2:ErrorContextText>EFilingBatchXML/Activity[1]/Party[25]/PartyIdentification[49]/PartyIdentificationNumberText</fc2:ErrorContextText>
<fc2:ErrorElementNameText/>	This element identifies the element name from the associated batch submission that triggered the error.	The value can be up to 512 characters.	<fc2:ErrorElementNameText>PartyIdentificationNumberText</fc2:ErrorElementNameText>
<fc2:ErrorLevelText/>	This element identifies the level of severity associated with the error.	This value, if an error is recorded, will always be "WARN" for "Warning".	<fc2:ErrorLevelText>WARN</fc2:ErrorLevelText>
<fc2:ErrorText/>	This element identifies the description of the error.	The value can be up to 512 characters.	<fc2:ErrorText>Filing Information: Type of filing (item 1) is

Element	Element Restrictions	Value Restrictions	Example
			missing</fc2:ErrorText>
<fc2:ErrorTypeCode/>	This element identifies the code associated with the error.	The value can be up to 50 characters.	<fc2:ErrorText>A1</fc2:ErrorText>
<fc2:EFilingActivityErrorXML/>			

5. Attachment A. Error Descriptions

The following table lists the RER errors that your batch may receive as a result of missing or invalid data. If your batch submission receives any of these validation errors, your entire batch submission will be REJECTED and you will need to take action to resolve the error(s) and resubmit the batch. For this reason, FinCEN strongly encourages that filers thoroughly test their XML batch filing process to ensure the RER batch files comply with:

- The published XML schema from an XML formatting perspective;
- The published Filing Instructions from an RER rule/reporting perspective; and
- The element/value restrictions described in this guide (which are consistent with the RER Filing Instructions).

Section/Part	Item name	Item #	Error Description	Error Code
NA	NA	NA	FormTypeCode is not recorded or is invalid. "RERX" must be recorded as the form type.	A0
Filing Information	Type of filing	1	Filing Information: Type of filing (item 1) is missing.	A1
Filing Information	Type of filing	1	Filing Information: Type of filing (item 1) exceeds the maximum occurrence threshold. Only one type of filing may be recorded.	A2
Filing Information	Prior report BSA Identifier	1bi	Filing Information: Prior report BSA Identifier (item 1bi) is missing. The BSA ID of the prior report (being corrected/amended) must be recorded.	A3
Filing Information	Prior report BSA Identifier	1bi	Filing Information: Prior report BSA Identifier (item 1bi) is invalid. A BSA ID may only be recorded with the type of filing is "Corrects/Amends prior report."	A4
Filing Information	Date prepared	2	Filing Information: Date prepared (item 2) is invalid. The date provided is not a valid date.	A5
Filing Information	Date prepared	2	Filing Information: Date prepared (item 2) is invalid. The date must be less than or equal to the date of submission.	A6
Part I. Reporting Person	Reporting Person Information	4-14	Part I. Reporting Person: Reporting Person Information (items 4-14) is missing. The reporting person must be recorded once for each RER.	B1

Section/Part	Item name	Item #	Error Description	Error Code
Part I. Reporting Person	Reporting Person Information	4-14	Part I. Reporting Person: Reporting Person Information (items 4-14) exceeds the maximum occurrence threshold. Only one reporting person may be recorded.	B2
Part I. Reporting Person	Reporting person category	4	Part I. Reporting Person: Reporting person category (item 4) is missing.	B3
Part I. Reporting Person	Reporting person category	4	Part I. Reporting Person: Reporting person category (item 4) exceeds the maximum occurrence threshold. Only one reporting person category may be recorded.	B4
Part I. Reporting Person	Last name or entity legal name	5	Part I. Reporting Person: Last name or entity legal name (item 5) is missing.	B5
Part I. Reporting Person	First name	7	Part I. Reporting Person: First name (item 7) is missing. A value must be provided when an individual is recorded.	B6
Part I. Reporting Person	First name	7	Part I. Reporting Person: First name (item 7) is invalid. First name must be empty for an entity.	B7
Part I. Reporting Person	Middle name	8	Part I. Reporting Person: Middle name (item 8) is invalid. Middle name must be empty for an entity.	B8
Part I. Reporting Person	Suffix	9	Part I. Reporting Person: Suffix (item 9) is invalid. Suffix must be empty for an entity.	B9
Part I. Reporting Person	Street address	10	Part I. Reporting Person: Street address (item 10) is missing.	B10
Part I. Reporting Person	City	11	Part I. Reporting Person: City (item 11) is missing.	B11
Part I. Reporting Person	U.S./U.S. Territory	12	Part I. Reporting Person: U.S./U.S. Territory (item 12) is missing.	B12

Section/Part	Item name	Item #	Error Description	Error Code
Part I. Reporting Person	U.S./U.S. Territory	12	Part I. Reporting Person: U.S./U.S. Territory (item 12) is invalid. Country/Jurisdiction must follow the 2-character ISO 3166 standard.	B13
Part I. Reporting Person	State/U.S. Territory	13	Part I. Reporting Person: State/U.S. Territory (item 13) is missing.	B14
Part I. Reporting Person	State/U.S. Territory	13	Part I. Reporting Person: State/U.S. Territory (item 13) is invalid. U.S. State / U.S. Territory codes must follow the 2-character ISO 3166 standard.	B15
Part I. Reporting Person	State/U.S. Territory	13	Part I. Reporting Person: State/U.S. Territory (item 13) is invalid. A U.S. Territory must be recorded as both country/jurisdiction and state.	B16
Part I. Reporting Person	ZIP code	14	Part I. Reporting Person: ZIP code (item 14) is missing.	B17
Part I. Reporting Person	ZIP code	14	Part I. Reporting Person: ZIP code (item 14) is invalid. A U.S. or U.S. Territory ZIP code must be 5 or 9 numeric characters. If recording a 5 numeric character ZIP code, do not include 4 trailing zeros (e.g. 220450000).	B18
Part I. Reporting Person	Date of closing	15	Part I. Reporting Person: Date of closing (item 15) is invalid. The date must be greater than or equal to 12/01/2025 but no greater than the date of filing.	B19
Part I. Reporting Person	Address Type	N/A	Part I. Reporting Person: Address Type is invalid. An Address Type must not be recorded.	B20
Part II. Property	Property Information	16-22	Part II. Property: Property Information (Items 16-22) is missing.	C1
Part II. Property	Property Information	16-22	Part II. Property: Property Information (item 16-22) exceeds the maximum occurrence threshold. No more than 999 properties may be recorded for a single RER.	C2
Part II. Property	Street address	16	Part II. Property: Street address (item 16) is missing. A value must be provided unless "No street address" is indicated.	C3

Section/Part	Item name	Item #	Error Description	Error Code
Part II. Property	Street address	16	Part II. Property: Street address (item 16) is invalid. The street address must be empty when "No street address" is indicated.	C4
Part II. Property	City	17	Part II. Property: City (item 17) is missing.	C5
Part II. Property	U.S./U.S. Territory	18	Part II. Property: U.S./U.S. Territory (item 18) is missing.	C6
Part II. Property	U.S./U.S. Territory	18	Part II. Property: U.S./U.S. Territory (item 18) is invalid. Country/Jurisdiction must follow the 2-character ISO 3166 standard.	C7
Part II. Property	State/U.S. Territory	19	Part II. Property: State/U.S. Territory (item 19) is missing.	C8
Part II. Property	State/U.S. Territory	19	Part II. Property: State/U.S. Territory (item 19) is invalid. U.S. State / U.S. Territory codes must follow the 2-character ISO 3166 standard.	C9
Part II. Property	State/U.S. Territory	19	Part II. Property: State/U.S. Territory (item 19) is invalid. A U.S. Territory must be recorded as both country/jurisdiction and state.	C10
Part II. Property	ZIP code	20	Part II. Property: ZIP code (item 20) is missing.	C11
Part II. Property	ZIP code	20	Part II. Property: ZIP code (item 20) is invalid. A U.S. or U.S. Territory ZIP code must be 5 or 9 numeric characters. If recording a 5 numeric character ZIP code, do not include 4 trailing zeros (e.g. 220450000).	C12
Part II. Property	Legal description type	21	Part II. Property: Legal description type (item 21) is missing.	C13
Part II. Property	Legal description type	21	Part II. Property: Legal description type (item 21) exceeds the maximum occurrence threshold. Only one legal description type may be recorded.	C14
Part II. Property	Other description	21d(i)	Part II. Property: Other description (item 21d(i)) is missing. A value must be provided when "Other" is indicated.	C15

Section/Part	Item name	Item #	Error Description	Error Code
Part II. Property	Other description	21d(i)	Part II. Property: Other description (item 21d(i)) is invalid. This item must be empty unless "Other" is indicated.	C16
Part II. Property	Legal description	22	Part II. Property: Legal description (item 22) is missing.	C17
Part III. Transferee	Transferee	23-38	Part III. Transferee: Transferee (Items 23-38) is missing.	D1
Part III. Transferee	Transferee Information	23-38	Part III. Transferee: Transferee Information (item 23-38) exceeds the maximum occurrence threshold. No more than 999 transferees may be recorded for a single RER.	D2
Part III. Transferee	Transferee type	23	Part III. Transferee: Transferee type (item 23) is missing.	D3
Part III. Transferee	Transferee type	23	Part III. Transferee: Transferee type (item 23) exceeds the maximum occurrence threshold. Only one transferee type may be recorded.	D4
Part III. Transferee	Date trust instrument was executed	24	Part III. Transferee: Date trust instrument was executed (item 24) is missing. A value must be provided when a trust is recorded.	D5
Part III. Transferee	Date trust instrument was executed	24	Part III. Transferee: Date trust instrument was executed (item 24) is invalid. This item must only be recorded for a trust.	D6
Part III. Transferee	Date trust instrument was executed	24	Part III. Transferee: Date trust instrument was executed (item 24) is invalid. (schema failure?)	D7
Part III. Transferee	Date trust instrument was executed	24	Part III. Transferee: Date trust instrument was executed (item 24) is invalid. The date must be less than or equal to the date of submission.	D8
Part III. Transferee	If revocable trust	25	Part III. Transferee: If revocable trust (item 25) is invalid. This item must only be recorded for a trust.	D9
Part III. Transferee	Total consideration paid	26	Part III. Transferee: Total consideration paid (item 26) is missing. A value must be provided unless "No consideration paid" is indicated.	D10

Section/Part	Item name	Item #	Error Description	Error Code
Part III. Transferee	Total consideration paid	26	Part III. Transferee: Total consideration paid (item 26) is invalid. The amount must be empty when "No consideration" is indicated.	D11
Part III. Transferee	Total consideration paid	26	Part III. Transferee: Total consideration paid (item 26) is invalid. The amount must contain numeric characters only (without leading zeros).	D12
Part III. Transferee	Total consideration paid	26	Part III. Transferee: Total consideration paid (item 26) is invalid. The amount cannot equal "0".	D13
Part III. Transferee	Legal name	27	Part III. Transferee: Legal name (item 27) is missing.	D14
Part III. Transferee	Alternate name	28	Part III. Transferee: Alternate name (item 28) is invalid. This item must be empty for a trust.	D15
Part III. Transferee	Foreign principal place of business with no U.S. location	29	Part III. Transferee: Foreign principal place of business with no U.S. location (item 29) is invalid. This item must be empty for a trust.	D16
Part III. Transferee	Foreign principal place of business with no U.S. location	29	Part III. Transferee: Foreign principal place of business with no U.S. location (item 29) is invalid. This item must not be indicated when a U.S. principal place of business address is recorded.	D17
Part III. Transferee	Foreign principal place of business with no U.S. location	29	Part III. Transferee: Foreign principal place of business with no U.S. location (item 29) is invalid. This item must not be indicated when a primary U.S. location address is recorded.	D18
Part III. Transferee	Address Information	30-35	Part III. Transferee: Address Information (item 30-35) is invalid. An address must not be recorded for a trust.	D19
Part III. Transferee	Address type	30	Part III. Transferee: Address type (item 30) is missing. The principal place of business must be provided for an entity.	D20
Part III. Transferee	Principal place of business (U.S.)	30a	Part III. Transferee: Principal place of business (U.S.) (item 30a) is missing. A principal place of business must be provided when an entity is recorded.	D21

Section/Part	Item name	Item #	Error Description	Error Code
Part III. Transferee	Foreign principal place of business (non-U.S.)	30b	Part III. Transferee: Foreign principal place of business (non-U.S.) (item 30b) is missing. The address of the foreign principal place of business must be provided for an entity when "Foreign principal place of business with no U.S. location" is indicated.	D22
Part III. Transferee	Primary U.S. location where entity conducts business	30c	Part III. Transferee: Primary U.S. location where entity conducts business (item 30c) is missing. The address of the primary U.S. location where the entity conducts business must be provided when a foreign principal place of business is recorded unless "Foreign principal place of business with no U.S. location" is indicated.	D23
Part III. Transferee	Street address	31	Part III. Transferee: Street address (item 31) is missing.	D24
Part III. Transferee	City	32	Part III. Transferee: City (item 32) is missing.	D25
Part III. Transferee	Country/Jurisdiction	33	Part III. Transferee: Country/Jurisdiction (item 33) is missing.	D26
Part III. Transferee	Country/Jurisdiction	33	Part III. Transferee: Country/Jurisdiction (item 33) is invalid. Country/Jurisdiction must follow the 2-character ISO 3166 standard.	D27
Part III. Transferee	Country/Jurisdiction	33	Part III. Transferee: Country/Jurisdiction (item 33) is invalid. The country/jurisdiction recorded does not align with the selected address type.	D28
Part III. Transferee	State/U.S. Territory	34	Part III. Transferee: State/U.S. Territory (item 34) is missing. A value must be provided when the corresponding country/jurisdiction is U.S., a U.S. Territory, Canada, or Mexico.	D29
Part III. Transferee	State/U.S. Territory	34	Part III. Transferee: State/U.S. Territory (item 34) is invalid. This item must be empty unless the corresponding country/jurisdiction is U.S., U.S. Territory, Canada, or Mexico.	D30
Part III. Transferee	State/U.S. Territory	34	Part III. Transferee: State/U.S. Territory (item 34) is invalid. U.S./Canadian states/territories/jurisdictions must follow the 2-character ISO 3166 standard.	D31

Section/Part	Item name	Item #	Error Description	Error Code
			Mexican states/territories/jurisdictions must follow the 3-character ISO 3166 standard.	
Part III. Transferee	State/U.S. Territory	34	Part III. Transferee: State/U.S. Territory (item 34) is invalid. A U.S. Territory must be recorded as both country/jurisdiction and state.	D32
Part III. Transferee	ZIP/Foreign postal code	35	Part III. Transferee: ZIP/Foreign postal code (item 35) is missing. A value must be provided when the corresponding country/jurisdiction is U.S., a U.S. Territory, Canada, or Mexico.	D33
Part III. Transferee	ZIP/Foreign postal code	35	Part III. Transferee: ZIP/Foreign postal code (item 35) is invalid. A U.S. or U.S. Territory ZIP code must be 5 or 9 numeric characters. If recording a 5 numeric character ZIP code, do not include 4 trailing zeros (e.g. 220450000).	D34
Part III. Transferee	Foreign entity registration number	36d	Part III. Transferee: Foreign entity registration number (item 36d) is invalid. This item must be empty for a trust.	D35
Part III. Transferee	Identification number	37	Part III. Transferee: Identification number (item 37) is missing. A value must be provided unless "No identification" is indicated.	D36
Part III. Transferee	Identification number	37	Part III. Transferee: Identification number (item 37) is invalid. This item must be empty when "No identification" is indicated.	D37
Part III. Transferee	Identification number	37	Part III. Transferee: Identification number (item 37) is invalid. The identification number must equal 9-numeric characters when EIN or SSN-ITIN is indicated for the identification type.	D38
Part III. Transferee	Identification number	37	Part III. Transferee: Identification number (item 37) is invalid. The identification number may only contain alphanumeric characters.	D39
Part III. Transferee	Identification number	37	Part III. Transferee: Identification number (item 37) is invalid. Identification numbers cannot equal "0" or all zeros.	D40
Part III. Transferee	[Foreign] Issuing jurisdiction	38	Part III. Transferee: [Foreign] Issuing jurisdiction (item 38) is missing. A value must be provided when a foreign identification type is recorded.	D41

Section/Part	Item name	Item #	Error Description	Error Code
Part III. Transferee	[Foreign] Issuing jurisdiction	38	Part III. Transferee: [Foreign] Issuing jurisdiction (item 38) is invalid. Foreign issuing jurisdiction must be empty unless a foreign identification type is recorded.	D42
Part III. Transferee	[Foreign] Issuing jurisdiction	38	Part III. Transferee: [Foreign] Issuing jurisdiction (item 38) is invalid. Foreign issuing jurisdiction must follow the 2-character ISO 3166 standard.	D43
Part III. Transferee	Address Type	30	Part III. Transferee: Address Type (item 30) is invalid. This item must be empty for a trust.	D44
Part III. Associated Person	Person(s) associated with this Transferee	39-60	Part III. Associated Person: Person(s) associated with this Transferee (Items 39-60) is missing.	E1
Part III. Associated Person	Person type	39	Part III. Associated Person: Person type (item 39) is missing.	E2
Part III. Associated Person	Trustee that is a Legal Entity	39c	Part III. Associated Person: Trustee that is a Legal Entity (item 39c) exceeds the maximum occurrence threshold. Unless the associated person is both the beneficial owner and signing individual, only one person type may be recorded.	E3
Part III. Associated Person	Parent/guardian information instead of minor child	40	Part III. Associated Person: Parent/guardian information instead of minor child (item 40) is invalid. This item is only applicable for a beneficial owner.	E4
Part III. Associated Person	Beneficial Owner Category	41	Part III. Associated Person: Beneficial Owner Category (item 41) is missing. At least one category must be indicated when a beneficial owner is recorded for a transferee trust.	E5
Part III. Associated Person	Beneficial Owner Category	41	Part III. Associated Person: Beneficial Owner Category (item 41) is invalid. This item is only applicable to a beneficial owner associated with a transferee trust.	E6
Part III. Associated Person	Beneficial Owner Category	41	Part III. Associated Person: Beneficial Owner Category (item 41) is invalid. This item is only applicable to a beneficial owner associated with a transferee trust.	E7

Section/Part	Item name	Item #	Error Description	Error Code
Part III. Associated Person	Country/Jurisdiction of citizenship	42	Part III. Associated Person: Country/Jurisdiction of citizenship (item 42) is missing. At least one country/jurisdiction of citizenship must be provided for a beneficial owner.	E8
Part III. Associated Person	Authorization capacity	43	Part III. Associated Person: Authorization capacity (item 43) is missing. A value must be provided when a signing individual is recorded.	E9
Part III. Associated Person	Authorization capacity	43	Part III. Associated Person: Authorization capacity (item 43) exceeds the maximum occurrence threshold. Only one authorization capacity type may be selected.	E10
Part III. Associated Person	Authorization capacity description	43	Part III. Associated Person: Authorization capacity description (item 43) is invalid. This item is only applicable for a signing individual.	E11
Part III. Associated Person	Other description	43f(i)	Part III. Associated Person: Other description (item 43f(i)) is missing. A value must be provided when "Other" is indicated.	E12
Part III. Associated Person	Other description	43f(i)	Part III. Associated Person: Other description (item 43f(i)) is invalid. This item must be empty unless "Other" is indicated.	E13
Part III. Associated Person	Name of employer, principal, partnership, etc.	44	Part III. Associated Person: Name of employer, principal, partnership, etc. (item 44) is missing. The name of the signing individual's employer, principal, partnership, etc., must be provided for the signing individual unless "Other" is indicated for the authorization capacity.	E14
Part III. Associated Person	Name of employer, principal, partnership, etc.	44	Part III. Associated Person: Name of employer, principal, partnership, etc. (item 44) is invalid. This item is only applicable for a signing individual.	E15
Part III. Associated Person	Last name or entity legal name	45	Part III. Associated Person: Last name or entity legal name (item 45) is missing.	E16
Part III. Associated Person	Alternate name	46	Part III. Associated Person: Alternate name (item 46) is invalid. This item is only applicable for a trustee entity.	E17
Part III. Associated Person	First name	47	Part III. Associated Person: First name (item 47) is missing. A value must be provided when an individual is recorded.	E18

Section/Part	Item name	Item #	Error Description	Error Code
Part III. Associated Person	First name	47	Part III. Associated Person: First name (item 47) is invalid. First name must be empty for an entity.	E19
Part III. Associated Person	Middle name	48	Part III. Associated Person: Middle name (item 48) is invalid. Middle name must be empty for an entity.	E20
Part III. Associated Person	Suffix	49	Part III. Associated Person: Suffix (item 49) is invalid. Suffix must be empty for an entity.	E21
Part III. Associated Person	Date of birth	50	Part III. Associated Person: Date of birth (item 50) is missing. A value must be provided when a beneficial owner and/or signing individual is recorded.	E22
Part III. Associated Person	Date of birth	50	Part III. Associated Person: Date of birth (item 50) is invalid. Date of birth must be empty for an entity.	E23
Part III. Associated Person	Date of birth	50	Part III. Associated Person: Date of birth (item 50) is invalid. (schema failure?)	E24
Part III. Associated Person	Date of birth	50	Part III. Associated Person: Date of birth (item 50) is invalid. The date cannot exceed the date of submission.	E25
Part III. Associated Person	Foreign principal place of business with no U.S. location	51	Part III. Associated Person: Foreign principal place of business with no U.S. location (item 51) is invalid. This item is not applicable for a beneficial owner/signing individual.	E26
Part III. Associated Person	Foreign principal place of business with no U.S. location	51	Part III. Associated Person: Foreign principal place of business with no U.S. location (item 51) is invalid. This item must be empty when a U.S. principal place of business is recorded.	E27
Part III. Associated Person	Address type	52	Part III. Associated Person: Address type (item 52) is missing. The principal place of business must be provided for an entity.	E28
Part III. Associated Person	Principal place of business (U.S.)	52a	Part III. Associated Person: Principal place of business (U.S.) (item 52a) is missing. A principal place of business must be provided when an entity is recorded.	E29

Section/Part	Item name	Item #	Error Description	Error Code
Part III. Associated Person	Foreign principal place of business (non-U.S.)	52b	Part III. Associated Person: Foreign principal place of business (non-U.S.) (item 52b) is missing. The address of the foreign principal place of business must be provided for an entity when "Foreign principal place of business with no U.S. location" is indicated.	E30
Part III. Associated Person	Primary U.S. location where entity conducts business	52c	Part III. Associated Person: Primary U.S. location where entity conducts business (item 52c) is missing. The address of the primary U.S. location where the entity conducts business must be provided when a foreign principal place of business is recorded unless "Foreign principal place of business with no U.S. location" is indicated.	E31
Part III. Associated Person	Street address	53	Part III. Associated Person: Street address (item 53) is missing.	E32
Part III. Associated Person	City	54	Part III. Associated Person: City (item 54) is missing.	E33
Part III. Associated Person	Country/Jurisdiction	55	Part III. Associated Person: Country/Jurisdiction (item 55) is missing.	E34
Part III. Associated Person	Country/Jurisdiction	55	Part III. Associated Person: Country/Jurisdiction (item 55) is invalid. Country/Jurisdiction must follow the 2-character ISO 3166 standard.	E35
Part III. Associated Person	Country/Jurisdiction	55	Part III. Associated Person: Country/Jurisdiction (item 55) is invalid. The country/jurisdiction recorded does not align with the selected address type.	E36
Part III. Associated Person	State/U.S. Territory	56	Part III. Associated Person: State/U.S. Territory (item 56) is missing. A value must be provided when the corresponding country/jurisdiction is U.S., a U.S. Territory, Canada, or Mexico.	E37
Part III. Associated Person	State/U.S. Territory	56	Part III. Associated Person: State/U.S. Territory (item 56) is invalid. This item must be empty unless the corresponding country/jurisdiction is U.S., U.S. Territory, Canada, or Mexico.	E38
Part III. Associated Person	State/U.S. Territory	56	Part III. Associated Person: State/U.S. Territory (item 56) is invalid. U.S./Canadian states/territories/jurisdictions must follow the 2-character ISO	E39

Section/Part	Item name	Item #	Error Description	Error Code
			3166 standard. Mexican states/territories/jurisdictions must follow the 3-character ISO 3166 standard.	
Part III. Associated Person	State/U.S. Territory	56	Part III. Associated Person: State/U.S. Territory (item 56) is invalid. A U.S. Territory must be recorded as both country/jurisdiction and state.	E40
Part III. Associated Person	ZIP/Foreign postal code	57	Part III. Associated Person: ZIP/Foreign postal code (item 57) is missing. A value must be provided when the corresponding country/jurisdiction is U.S., a U.S. Territory, Canada, or Mexico.	E41
Part III. Associated Person	ZIP/Foreign postal code	57	Part III. Associated Person: ZIP/Foreign postal code (item 57) is invalid. A U.S. or U.S. Territory ZIP code must be 5 or 9 numeric characters. If recording a 5 numeric character ZIP code, do not include 4 trailing zeros (e.g. 220450000).	E42
Part III. Associated Person	Foreign passport	58d	Part III. Associated Person: Foreign passport (item 58d) is invalid. This item is not applicable for a trustee entity.	E43
Part III. Associated Person	No identification (if trustee entity with no identification)	58f	Part III. Associated Person: No identification (if trustee entity with no identification) (item 58f) is invalid. "No identification" is not a valid selection for an individual.	E44
Part III. Associated Person	Identification number	59	Part III. Associated Person: Identification number (item 59) is missing. A value must be provided unless "No identification" is indicated.	E45
Part III. Associated Person	Identification number	59	Part III. Associated Person: Identification number (item 59) is invalid. Identification number must be empty when "No identification" is indicated.	E46
Part III. Associated Person	Identification number	59	Part III. Associated Person: Identification number (item 59) is invalid. The identification number must equal 9-numeric characters when EIN or SSN-ITIN is indicated for the identification type.	E47
Part III. Associated Person	Identification number	59	Part III. Associated Person: Identification number (item 59) is invalid. The identification number may only contain alphanumeric characters.	E48
Part III. Associated Person	Identification number	59	Part III. Associated Person: Identification number (item 59) is invalid. Identification numbers cannot equal "0" or all zeros.	E49

Section/Part	Item name	Item #	Error Description	Error Code
Part III. Associated Person	[Foreign] Issuing jurisdiction	60	Part III. Associated Person: [Foreign] Issuing jurisdiction (item 60) is missing. A value must be provided when a foreign identification type is recorded.	E50
Part III. Associated Person	[Foreign] Issuing jurisdiction	60	Part III. Associated Person: [Foreign] Issuing jurisdiction (item 60) is invalid. This item must be empty unless a foreign identification type is indicated.	E51
Part III. Associated Person	[Foreign] Issuing jurisdiction	60	Part III. Associated Person: [Foreign] Issuing jurisdiction (item 60) is invalid. Foreign issuing jurisdiction must follow the 2-character ISO 3166 standard.	E52
Part III. Associated Person	Address Type	52	Part III. Associated Person: Address Type (item 52) is invalid. This item is only applicable for a trustee entity.	E53
Part IV. Transferor	Transferor	61-78	Part IV. Transferor: Transferor (Items 61-78) is missing.	F1
Part IV. Transferor	Transferor Information	61-78	Part IV. Transferor: Transferor Information (item 61-78) exceeds the maximum occurrence threshold. No more than 999 transferors may be recorded for a single RER.	F2
Part IV. Transferor	Date trust instrument was executed	62	Part IV. Transferor: Date trust instrument was executed (item 62) is missing. A value must be provided when a trust is recorded.	F3
Part IV. Transferor	Date trust instrument was executed	62	Part IV. Transferor: Date trust instrument was executed (item 62) is invalid. This item must only be recorded for a trust.	F4
Part IV. Transferor	Date trust instrument was executed	62	Part IV. Transferor: Date trust instrument was executed (item 62) is invalid. (schema failure?)	F5
Part IV. Transferor	Date trust instrument was executed	62	Part IV. Transferor: Date trust instrument was executed (item 62) is invalid. The date must be less than or equal to the date of submission.	F6
Part IV. Transferor	Legal name or entity legal name	63	Part IV. Transferor: Legal name or entity legal name (item 63) is missing.	F7
Part IV. Transferor	Alternate name	64	Part IV. Transferor: Alternate name (item 64) is invalid. This item is only applicable to a transferor entity.	F8

Section/Part	Item name	Item #	Error Description	Error Code
Part IV. Transferor	First name	65	Part IV. Transferor: First name (item 65) is missing. A value must be provided when an individual is recorded.	F9
Part IV. Transferor	First name	65	Part IV. Transferor: First name (item 65) is invalid. First name must be empty for an entity or trust.	F10
Part IV. Transferor	Middle name	66	Part IV. Transferor: Middle name (item 66) is invalid. Middle name must be empty for an entity or trust.	F11
Part IV. Transferor	Suffix	67	Part IV. Transferor: Suffix (item 67) is invalid. Suffix must be empty for an entity or trust.	F12
Part IV. Transferor	Date of birth	68	Part IV. Transferor: Date of birth (item 68) is missing. A value must be provided when a beneficial owner and/or signing individual is recorded.	F13
Part IV. Transferor	Date of birth	68	Part IV. Transferor: Date of birth (item 68) is invalid. Date of birth must be empty for an entity.	F14
Part IV. Transferor	Date of birth	68	Part IV. Transferor: Date of birth (item 68) is invalid. (schema failure?)	F15
Part IV. Transferor	Date of birth	68	Part IV. Transferor: Date of birth (item 68) is invalid. The date cannot exceed the date of submission.	F16
Part IV. Transferor	Foreign principal place of business with no U.S. location	69	Part IV. Transferor: Foreign principal place of business with no U.S. location (item 69) is invalid. This item is only applicable for a transferor entity.	F17
Part IV. Transferor	Foreign principal place of business with no U.S. location	69	Part IV. Transferor: Foreign principal place of business with no U.S. location (item 69) is invalid. This item must be empty when a U.S. principal place of business is recorded.	F18
Part IV. Transferor	Foreign principal place of business with no U.S. location	69	Part IV. Transferor: Foreign principal place of business with no U.S. location (item 69) is invalid. This item must not be indicated when a primary U.S. location address is recorded.	F19

Section/Part	Item name	Item #	Error Description	Error Code
Part IV. Transferor	Address Information	70-75	Part IV. Transferor: Address Information (item 70-75) is missing. A residential address (if individual) or principal place of business address (if entity) must be provided.	F20
Part IV. Transferor	Address Information	70-75	Part IV. Transferor: Address Information (item 70-75) is invalid. This item must be empty for a trust.	F21
Part IV. Transferor	Address type	70	Part IV. Transferor: Address type (item 70) is missing. The principal place of business must be provided for an entity.	F22
Part IV. Transferor	Principal place of business (U.S.)	70a	Part IV. Transferor: Principal place of business (U.S.) (item 70a) is missing. A principal place of business must be provided when an entity is recorded.	F23
Part IV. Transferor	Foreign principal place of business (non-U.S.)	70b	Part IV. Transferor: Foreign principal place of business (non-U.S.) (item 70b) is missing. The address of the foreign principal place of business must be provided for an entity when "Foreign principal place of business with no U.S. location" is indicated.	F24
Part IV. Transferor	Primary U.S. location where entity conducts business	70c	Part IV. Transferor: Primary U.S. location where entity conducts business (item 70c) is missing. The address of the primary U.S. location where the entity conducts business must be provided when a foreign principal place of business is recorded unless "Foreign principal place of business with no U.S. location" is indicated.	F25
Part IV. Transferor	Street address	71	Part IV. Transferor: Street address (item 71) is missing.	F26
Part IV. Transferor	City	72	Part IV. Transferor: City (item 72) is missing.	F27
Part IV. Transferor	Country/Jurisdiction	73	Part IV. Transferor: Country/Jurisdiction (item 73) is missing.	F28
Part IV. Transferor	Country/Jurisdiction	73	Part IV. Transferor: Country/Jurisdiction (item 73) is invalid. Country/Jurisdiction must follow the 2-character ISO 3166 standard.	F29

Section/Part	Item name	Item #	Error Description	Error Code
Part IV. Transferor	Country/Jurisdiction	73	Part IV. Transferor: Country/Jurisdiction (item 73) is invalid. The country/jurisdiction recorded does not align with the selected address type.	F30
Part IV. Transferor	State/U.S. Territory	74	Part IV. Transferor: State/U.S. Territory (item 74) is missing. A value must be provided when the corresponding country/jurisdiction is U.S., a U.S. Territory, Canada, or Mexico.	F31
Part IV. Transferor	State/U.S. Territory	74	Part IV. Transferor: State/U.S. Territory (item 74) is invalid. This item must be empty unless the corresponding country/jurisdiction is U.S., U.S. Territory, Canada, or Mexico.	F32
Part IV. Transferor	State/U.S. Territory	74	Part IV. Transferor: State/U.S. Territory (item 74) is invalid. U.S./Canadian states/territories/jurisdictions must follow the 2-character ISO 3166 standard. Mexican states/territories/jurisdictions must follow the 3-character ISO 3166 standard.	F33
Part IV. Transferor	State/U.S. Territory	74	Part IV. Transferor: State/U.S. Territory (item 74) is invalid. A U.S. Territory must be recorded as both country/jurisdiction and state.	F34
Part IV. Transferor	ZIP/Foreign postal code	75	Part IV. Transferor: ZIP/Foreign postal code (item 75) is missing. A value must be provided when the corresponding country/jurisdiction is U.S., a U.S. Territory, Canada, or Mexico.	F35
Part IV. Transferor	ZIP/Foreign postal code	75	Part IV. Transferor: ZIP/Foreign postal code (item 75) is invalid. A U.S. or U.S. Territory ZIP code must be 5 or 9 numeric characters. If recording a 5 numeric character ZIP code, do not include 4 trailing zeros (e.g. 220450000).	F36
Part IV. Transferor	Foreign passport	76d	Part IV. Transferor: Foreign passport (item 76d) is invalid. This item must be empty when the corresponding transferor is an entity or a trust.	F37
Part IV. Transferor	Foreign entity registration number	76e	Part IV. Transferor: Foreign entity registration number (item 76e) is invalid. This item must be empty for a trust.	F38
Part IV. Transferor	No identification (if transferor entity or trust only)	76f	Part IV. Transferor: No identification (if transferor entity or trust only) (item 76f) is invalid. "No identification" is not a valid selection for an individual.	F39

Section/Part	Item name	Item #	Error Description	Error Code
Part IV. Transferor	Identification number	77	Part IV. Transferor: Identification number (item 77) is missing. A value must be provided unless "No identification" is indicated.	F40
Part IV. Transferor	Identification number	77	Part IV. Transferor: Identification number (item 77) is invalid. Identification number must be empty when "No identification" is indicated.	F41
Part IV. Transferor	Identification number	77	Part IV. Transferor: Identification number (item 77) is invalid. The identification number must equal 9-numeric characters when EIN or SSN-ITIN is indicated for the identification type.	F42
Part IV. Transferor	Identification number	77	Part IV. Transferor: Identification number (item 77) is invalid. The identification number may only contain alphanumeric characters.	F43
Part IV. Transferor	Identification number	77	Part IV. Transferor: Identification number (item 77) is invalid. Identification numbers cannot equal "0" or all zeros.	F44
Part IV. Transferor	[Foreign] Issuing jurisdiction	78	Part IV. Transferor: [Foreign] Issuing jurisdiction (item 78) is missing. A value must be provided when a foreign identification type is recorded.	F45
Part IV. Transferor	[Foreign] Issuing jurisdiction	78	Part IV. Transferor: [Foreign] Issuing jurisdiction (item 78) is invalid. This item must be empty unless a foreign identification type is indicated.	F46
Part IV. Transferor	[Foreign] Issuing jurisdiction	78	Part IV. Transferor: [Foreign] Issuing jurisdiction (item 78) is invalid. Foreign issuing jurisdiction must follow the 2-character ISO 3166 standard.	F47
Part IV. Transferor	Address Type	70	Part IV. Transferor: Address Type (item 70) is invalid. This item is only applicable for an entity.	F48
Part IV. Trustee	Trustee Information	79-94	Part IV. Trustee: Trustee Information (item 79-94) is missing. At least one trustee must be recorded for the transferor trust.	G1
Part IV. Trustee	Trustee Information	79-94	Part IV. Trustee: Trustee Information (item 79-94) exceeds the maximum occurrence threshold. No more than 99 trustees may be recorded for a single transferor trust.	G2

Section/Part	Item name	Item #	Error Description	Error Code
Part IV. Trustee	Trustee Information	79-94	Part IV. Trustee: Trustee Information (item 79-94) is invalid. A trustee may only be recorded when the associated transferor is a trust.	G3
Part IV. Trustee	Last name or entity legal name	79	Part IV. Trustee: Last name or entity legal name (item 79) is missing.	G4
Part IV. Trustee	Alternate name	81	Part IV. Trustee: Alternate name (item 81) is invalid. This item is only applicable to a trustee entity.	G5
Part IV. Trustee	First name	82	Part IV. Trustee: First name (item 82) is missing. A value must be provided when an individual is recorded.	G6
Part IV. Trustee	First name	82	Part IV. Trustee: First name (item 82) is invalid. First name must be empty for an entity.	G7
Part IV. Trustee	Middle name	83	Part IV. Trustee: Middle name (item 83) is invalid. Middle name must be empty for an entity.	G8
Part IV. Trustee	Suffix	84	Part IV. Trustee: Suffix (item 84) is invalid. Suffix must be empty for an entity.	G9
Part IV. Trustee	Foreign principal place of business with no U.S. location	85	Part IV. Trustee: Foreign principal place of business with no U.S. location (item 85) is invalid. This item is only applicable for a trustee entity.	G10
Part IV. Trustee	Address Information	86-91	Part IV. Trustee: Address Information (items 86-91) is missing. A residential address (if individual) or principal place of business address (if entity) must be provided.	G11
Part IV. Trustee	Address type	86	Part IV. Trustee: Address type (item 86) is missing. The principal place of business must be provided for an entity.	G12
Part IV. Trustee	Principal place of business (U.S.)	86a	Part IV. Trustee: Principal place of business (U.S.) (item 86a) is missing. A principal place of business must be provided when an entity is recorded.	G13

Section/Part	Item name	Item #	Error Description	Error Code
Part IV. Trustee	Foreign principal place of business (non-U.S.)	86b	Part IV. Trustee: Foreign principal place of business (non-U.S.) (item 86b) is missing. The address of the foreign principal place of business must be provided for an entity when "Foreign principal place of business with no U.S. location" is indicated.	G14
Part IV. Trustee	Primary U.S. location where entity conducts business	86c	Part IV. Trustee: Primary U.S. location where entity conducts business (item 86c) is missing. The address of the primary U.S. location where the entity conducts business must be provided when a foreign principal place of business is recorded unless "Foreign principal place of business with no U.S. location" is indicated.	G15
Part IV. Trustee	Street address	87	Part IV. Trustee: Street address (item 87) is missing.	G16
Part IV. Trustee	City	88	Part IV. Trustee: City (item 88) is missing.	G17
Part IV. Trustee	Country/Jurisdiction	89	Part IV. Trustee: Country/Jurisdiction (item 89) is missing.	G18
Part IV. Trustee	Country/Jurisdiction	89	Part IV. Trustee: Country/Jurisdiction (item 89) is invalid. Country/Jurisdiction must follow the 2-character ISO 3166 standard.	G19
Part IV. Trustee	Country/Jurisdiction	89	Part IV. Trustee: Country/Jurisdiction (item 89) is invalid. The country/jurisdiction recorded does not align with the selected address type.	G20
Part IV. Trustee	State/U.S. Territory	90	Part IV. Trustee: State/U.S. Territory (item 90) is missing. A value must be provided when the corresponding country/jurisdiction is U.S., a U.S. Territory, Canada, or Mexico.	G21
Part IV. Trustee	State/U.S. Territory	90	Part IV. Trustee: State/U.S. Territory (item 90) is invalid. This item must be empty unless the corresponding country/jurisdiction is U.S., U.S. Territory, Canada, or Mexico.	G22
Part IV. Trustee	State/U.S. Territory	90	Part IV. Trustee: State/U.S. Territory (item 90) is invalid. U.S./Canadian states/territories/jurisdictions must follow the 2-character ISO 3166 standard.	G23

Section/Part	Item name	Item #	Error Description	Error Code
			Mexican states/territories/jurisdictions must follow the 3-character ISO 3166 standard.	
Part IV. Trustee	State/U.S. Territory	90	Part IV. Trustee: State/U.S. Territory (item 90) is invalid. A U.S. Territory must be recorded as both country/jurisdiction and state.	G24
Part IV. Trustee	ZIP/Foreign postal code	91	Part IV. Trustee: ZIP/Foreign postal code (item 91) is missing. A value must be provided when the corresponding country/jurisdiction is U.S., a U.S. Territory, Canada, or Mexico.	G25
Part IV. Trustee	ZIP/Foreign postal code	91	Part IV. Trustee: ZIP/Foreign postal code (item 91) is invalid. A U.S. or U.S. Territory ZIP code must be 5 or 9 numeric characters. If recording a 5 numeric character ZIP code, do not include 4 trailing zeros (e.g. 220450000).	G26
Part IV. Trustee	Foreign passport	92d	Part IV. Trustee: Foreign passport (item 92d) is invalid. This item is not applicable to a trustee entity.	G27
Part IV. Trustee	No identification (if entity only)	92f	Part IV. Trustee: No identification (if entity only) (item 92f) is invalid. "No identification" is not a valid selection for an individual.	G28
Part IV. Trustee	Identification number	93	Part IV. Trustee: Identification number (item 93) is missing. A value must be provided unless "No identification" is indicated.	G29
Part IV. Trustee	Identification number	93	Part IV. Trustee: Identification number (item 93) is invalid. Identification number must be empty when "No identification" is indicated.	G30
Part IV. Trustee	Identification number	93	Part IV. Trustee: Identification number (item 93) is invalid. The identification number must equal 9-numeric characters when EIN or SSN-ITIN is indicated for the identification type.	G31
Part IV. Trustee	Identification number	93	Part IV. Trustee: Identification number (item 93) is invalid. The identification number may only contain alphanumeric characters.	G32
Part IV. Trustee	Identification number	93	Part IV. Trustee: Identification number (item 93) is invalid. Identification numbers cannot equal "0" or all zeros.	G33

Section/Part	Item name	Item #	Error Description	Error Code
Part IV. Trustee	[Foreign] Issuing jurisdiction	94	Part IV. Trustee: [Foreign] Issuing jurisdiction (item 94) is missing. A value must be provided when a foreign identification type is recorded.	G34
Part IV. Trustee	[Foreign] Issuing jurisdiction	94	Part IV. Trustee: [Foreign] Issuing jurisdiction (item 94) is invalid. This item must be empty unless a foreign identification type is indicated.	G35
Part IV. Trustee	[Foreign] Issuing jurisdiction	94	Part IV. Trustee: [Foreign] Issuing jurisdiction (item 94) is invalid. Foreign issuing jurisdiction must follow the 2-character ISO 3166 standard.	G36
Part IV. Trustee	Address Type	86	Part IV. Trustee: Address Type (item 86) is invalid. This item is only applicable for a trustee entity.	G37
Part V. Payment	Total consideration paid	95	Part V. Payment: Total consideration paid (item 95) is missing. A value must be provided unless "No consideration paid" is indicated.	H1
Part V. Payment	Total consideration paid	95	Part V. Payment: Total consideration paid (item 95) is invalid. The amount must be empty when "No consideration" is indicated.	H2
Part V. Payment	Total consideration paid	95	Part V. Payment: Total consideration paid (item 95) is invalid. The amount must contain numeric characters only (without leading zeros).	H3
Part V. Payment	Total consideration paid	95	Part V. Payment: Total consideration paid (item 95) is invalid. The amount cannot equal "0".	H4
Part V. Payment	Type of hard money, private, and other similar loans	97	Part V. Payment: Type of hard money, private, and other similar loans (item 97) is missing. A value must be provided when "Hard money, private, or other similar loans involved in reportable transfer" is indicated.	H5
Part V. Payment	Type of hard money, private, and other similar loans	97	Part V. Payment: Type of hard money, private, and other similar loans (item 97) is invalid. A value should not be recorded when "Hard money, private, or other similar loans involved in reportable transfer" is empty.	H6
Part V. Payment	Other description	97d(i)	Part V. Payment: Other description (item 97d(i)) is missing. A value must be provided when "Other" is indicated.	H7

Section/Part	Item name	Item #	Error Description	Error Code
Part V. Payment	Other description	97d(i)	Part V. Payment: Other description (item 97d(i)) is invalid. This item must be empty unless "Other" is indicated.	H8
Part V. Payment	Payment made by or on behalf of the Transferee entity/trust	98-111	Part V. Payment: Payment made by or on behalf of the Transferee entity/trust (items 98-111) is missing.	H9
Part V. Payment	Payment value amount	98	Part V. Payment: Payment value amount (item 98) is invalid. The amount must contain numeric characters only (without leading zeros).	H10
Part V. Payment	Payment value amount	98	Part V. Payment: Payment value amount (item 98) is invalid. The amount cannot equal "0".	H11
Part V. Payment	Other description	99i(i)	Part V. Payment: Other description (item 99i(i)) is missing. A value must be provided when "Other" is indicated.	H12
Part V. Payment	Other description	99i(i)	Part V. Payment: Other description (item 99i(i)) is invalid. This item must be empty unless "Other" is indicated.	H13
Part V. Payment	Foreign currency code	100	Part V. Payment: Foreign currency code (item 100) is missing. A value must be provided when "foreign currency" is indicated for the payment method.	H14
Part V. Payment	[Foreign payment] Currency code	100	Part V. Payment: [Foreign payment] Currency code (item 100) is invalid. Foreign currency code must be empty when "U.S. currency" is indicated for the payment method.	H15
Part V. Payment	Foreign currency code other description	100a	Part V. Payment: Foreign currency code other description (item 100a) is missing. A value must be provided when "Other" is indicated for the foreign currency code.	H16
Part V. Payment	[Foreign currency] Other description	100a	Part V. Payment: [Foreign currency] Other description (item 100a) is invalid. Foreign currency code other description must be empty unless "Other" is indicated for the foreign currency code.	H17

Section/Part	Item name	Item #	Error Description	Error Code
Part V. Payment	Account number	102	Part V. Payment: Account number (item 102) is missing. A value must be provided unless "Payment is not from a financial institution account" is indicated.	H18
Part V. Payment	Account number	102	Part V. Payment: Account number (item 102) is invalid. Account number is not applicable when "Payment is not from a financial institution account" is indicated.	H19
Part V. Payment	Financial institution legal name	103	Part V. Payment: Financial institution legal name (item 103) is missing. A value must be provided unless "Payment is not from a financial institution account" is indicated.	H20
Part V. Payment	Financial institution legal name	103	Part V. Payment: Financial institution legal name (item 103) is invalid. Financial institution name (where account is held) is not applicable when "Payment is not from a financial institution account" is indicated.	H21
Part V. Payment	Associated transferee legal name	105	Part V. Payment: Associated transferee legal name (item 105) is missing. A value must be provided unless "Payment associated with all recorded transferees in Part III" is indicated.	H22
Part V. Payment	Associated transferee legal name	105	Part V. Payment: Associated transferee legal name (item 105) exceeds the maximum occurrence threshold. No more than 999 associated transferee names may be recorded for a single payment.	H23
Part V. Payment	Associated transferee legal name	105	Part V. Payment: Associated transferee legal name (item 105) is invalid. Associated transferee name is not applicable when "Payment associated with all recorded transferees in Part III" is indicated.	H24
Part V. Payment	Associated transferee legal name	105	Part V. Payment: Associated transferee legal name (item 105) is invalid. The name recorded does not match a recorded transferee in Part III.	H25
Part V. Payment	Payor Information	107-111	Part V. Payment: Payor Information (item 107-111) is missing. Payor information must be provided unless "all payors are all recorded transferees in Part III or all recorded transferees in item 105" is indicated.	H26

Section/Part	Item name	Item #	Error Description	Error Code
Part V. Payment	Payor Information	107-111	Part V. Payment: Payor Information (item 107-111) is invalid. Payor information is not applicable when "All payors are all recorded transferees in Part III or all recorded transferees in item 105" is indicated.	H27
Part V. Payment	Last name or entity legal name	107	Part V. Payment: Last name or entity legal name (item 107) is missing.	H28
Part V. Payment	First name	109	Part V. Payment: First name (item 109) is missing. A value must be provided when an individual is recorded.	H29
Part V. Payment	First name	109	Part V. Payment: First name (item 109) is invalid. First name must be empty for an entity.	H30
Part V. Payment	Middle name	110	Part V. Payment: Middle name (item 110) is invalid. Middle name must be empty for an entity.	H31
Part V. Payment	Suffix	111	Part V. Payment: Suffix (item 111) is invalid. Suffix must be empty for an entity.	H32
Transmitter	Not Applicable	NA	Transmitter is missing. A required party associated with the transmitter is missing.	T1
Transmitter	Not Applicable	NA	Transmitter exceeds the maximum occurrence threshold. The report contains more than one party associated with the transmitter.	T2
Transmitter	Transmitter Name	NA	Transmitter: Transmitter Name is missing. The element is not recorded or does not contain a value.	T3
Transmitter	Transmitter Address	NA	Transmitter: Transmitter Address is missing. The element is not recorded or does not contain a value.	T4
Transmitter	Transmitter City	NA	Transmitter: Transmitter City is missing. The element is not recorded or does not contain a value.	T5
Transmitter	Transmitter State	NA	Transmitter: Transmitter State is missing. The element is not recorded or does not contain a value.	T6

Section/Part	Item name	Item #	Error Description	Error Code
Transmitter	Transmitter State	NA	Transmitter: Transmitter State is invalid. The element contains a value that is not a valid code.	T7
Transmitter	Transmitter State	NA	Transmitter: Transmitter State is invalid. State code and country code mismatch when U.S. Territory is recorded.	T8
Transmitter	Transmitter ZIP/Postal Code	NA	Transmitter: Transmitter ZIP/Postal Code is missing. The element is not recorded or does not contain a value.	T9
Transmitter	Transmitter ZIP/Postal Code	NA	Transmitter: Transmitter ZIP/Postal Code is invalid. The value recorded contains nonnumeric characters or is in an invalid format and the country is U.S. or a U.S. Territory.	T10
Transmitter	Transmitter Country	NA	Transmitter: Transmitter Country is missing. The element is not recorded or does not contain a value.	T11
Transmitter	Transmitter Country	NA	Transmitter: Transmitter Country is invalid. The element contains a value that is not a valid code.	T12
Transmitter	Transmitter TIN	NA	Transmitter: Transmitter TIN is invalid. The element contains an invalid number string for a U.S. TIN.	T14
Transmitter	Transmitter TIN	NA	Transmitter: Transmitter TIN is missing. The element is not recorded or does not contain a value.	T15
Transmitter	Transmitter TIN Type and Transmitter TCC Type	NA	Transmitter: Transmitter TIN Type or Transmitter TCC Type is invalid. The element contains a value that is not a valid code.	T17
Transmitter	Transmitter TCC	NA	Transmitter: Transmitter TCC is invalid. The Transmitter Control Code (TCC) specified in the file is not a valid TCC. For testing in SANDBOX, the TCC must be "TBSATEST".	T18
Transmitter	Transmitter ZIP/Postal Code	NA	Transmitter: Transmitter ZIP/Postal Code is invalid. The value recorded contains special characters or formatting such as hyphens, periods, and spaces.	T21

Section/Part	Item name	Item #	Error Description	Error Code
Transmitter	Transmitter Telephone Number	NA	Transmitter: Transmitter Telephone Number is invalid. The value recorded for the element contains non-numeric characters.	T22
Transmitter	Transmitter Telephone Number	NA	Transmitter: Transmitter Telephone Number is missing. The element is not recorded or does not contain a value (i.e. the value is null).	T23
Transmitter	Address Type	NA	Transmitter: Transmitter Address Type is invalid. An Address Type must not be recorded.	T27
Transmitter Contact	Not Applicable	NA	Transmitter Contact is missing. A required party associated with the transmitter contact is missing.	T24
Transmitter Contact	Not Applicable	NA	Transmitter Contact exceeds the maximum occurrence threshold. The report contains more than one party associated with the transmitter contact.	T25
Transmitter Contact	Transmitter Contact Name	NA	Transmitter Contact: Transmitter Contact Name is missing. The element is not recorded or does not contain a value.	T26
Country/Jurisdiction	Country/Jurisdiction	Multiple	Country/Jurisdiction is invalid. Country/Jurisdiction must follow the 2-character ISO 3166 standard.	X1
State/U.S. Territory	State/U.S. Territory	Multiple	State/U.S. Territory is invalid. U.S./Canadian states/territories/jurisdictions must follow the 2-character ISO 3166 standard. Mexican states/territories/jurisdictions must follow the 3-character ISO 3166 standard.	X2
Country/Jurisdiction	Country/Jurisdiction	Multiple	Country/Jurisdiction is missing. Country/Jurisdiction must be recorded if state is recorded.	X3
NA	NA	NA	Elements must contain a value. Element: ELEMENT_NAME	Y1
Multiple	NA	NA	Party contains invalid child elements.	Y2

Section/Part	Item name	Item #	Error Description	Error Code
Multiple	NA	NA	PartyAssociation contains invalid child elements.	Y3
Multiple	NA	NA	PartyName contains invalid child elements.	Y4
NA	NA	NA	Invalid Party Type under Activity. Only types 35, 37, 31, 67, or 69 are allowed here	Z1
NA	NA	NA	Invalid Child Party. A Transferee (67) can only contain an Associated Person (68).	Z2
NA	NA	NA	Invalid Child Party. An Associated Person (68) can only contain Party Type (73).	Z3
NA	NA	NA	Invalid Child Party. A Transferor (69) can only contain a Trustee (70).	Z4
NA	NA	NA	Invalid Party Type under ValueTransferActivityDetail. Only types 41, 71, or 72 are allowed here.	Z5
NA	NA	NA	The report contains a Party (Type other than 67, 68, 69, or 70) with an invalid number of PartyName elements. Exactly one PartyName is required.	Z6
NA	NA	NA	The Transmitter (Type 35) must have exactly 2 PartyIdentification elements.	Z7
NA	NA	NA	This Party type (31, 37, 41, 71, 72, or 73) must not have any PartyIdentification elements recorded	Z8
NA	NA	NA	This Party type (67, 68, 69, or 70) must have exactly 1 PartyIdentification element.	Z9
NA	NA	NA	This Party Type (35, 37, 31, 73, 70, 41, 71, or 72) must not contain PartyAssociation elements	Z10

Section/Part	Item name	Item #	Error Description	Error Code
NA	NA	NA	When only one Party Name is recorded, the Name Type Code must be 'L' (Legal).	Z11
NA	NA	NA	This Party type must have exactly 1 address element.	Z12
NA	NA	NA	This Party type must have 0 address elements.	Z13
NA	NA	NA	RawPartyFullName must be used for an alternate name.	Z14
NA	NA	NA	The ActivityCount attribute must match the actual number of Activity elements. Expected: #, Found: #	Z15

6. Attachment B. Server-to-Server “SDTM” Submission Automation

FinCEN provides the ability for filers to submit batch data directly to the BSA E-Filing server over a secure connection using Secure File Transfer Protocol (SFTP). This method of filing is referred to as Secure Direct Transfer Mode (SDTM). SDTM allows the batch submission process to be automated such that user intervention/involvement is minimized. To set up SDTM batch filing, please refer to the following document: [BSA E-Filing SDTM Requirements](#)

6.1. SDTM Batch File Naming Convention

The file naming convention is as follows:

<Submission-Type>.<Date/Timestamp>.<SDTM-Username>.xml

e.g., RERXST.20250525165959.sdtmtitle123.xml

- Submission-Type: This will always be RERXST
- Date/Timestamp: This will be the date/timestamp to guarantee filename uniqueness
YYYYMMDDhhmmss
 - YYYY=Year (e.g., 2025)
 - MM=Month (e.g., 05)
 - DD=Day (e.g., 25)
 - hh=Hour (e.g., 16)
 - mm=Minute (e.g., 59)
 - ss=Second (e.g., 59)
- SDTM-Username: This will be the unique username created by FinCEN for your SDTM account.

6.2. SDTM Submission Response Files

After successful submission of your RER batch XML, FinCEN will return two response files:

1. Messages file. Within a few hours of submission, FinCEN returns a “messages” file in XML format with the status of your submission (e.g., accepted or rejected) and any errors associated with the submission. The name of this file will match your batch file name but with *.MESSAGES.XML appended to the end of the name. The schema associated with this XML is located here: www.bsaefiling.fincen.gov/resources/MESSAGES.xsd
2. Acknowledgement file. Within 1-2 business days after an *accepted* submission, FinCEN returns an “acknowledgement” file in XML format with the BSA Identifier assigned to each RER in your batch. The name of this file will match your batch file name but with *.ACKED appended to the end of the name. See [Section 4 RER XML Batch Acknowledgement](#) for details about this file.

6.3. SDTM Account Creation

If you are interested in establishing an SDTM account to automate the submission of RER batches, go to <https://bsaefiling.fincen.gov/help-ticket> to create a support ticket with the category “Secure Data Transfer (SFTP)” and subcategory “New Account Setup” (please be sure to include details about your organization and whether or not you have an existing BSA E-Filing account in the Issue Description.)

NOTE: The Help Desk is available Mon-Fri from 8AM to 6PM ET and is closed on Federal holidays.

Revision History

Version	Date	Change Description
1.0	Dec 2025	Initial draft
1.0.1	Feb 2026	<ul style="list-style-type: none"> • 3.7.1.2.1 Party: Financial Institution (FI) where account held <ul style="list-style-type: none"> ○ Page 71 <ul style="list-style-type: none"> ▪ Removed the following elements after AccountNumberText, as these are not applicable and were never part of the associated schema: <ul style="list-style-type: none"> • <fc2:PartyAccountAssociation SeqNum="#"> • <fc2:PartyAccountAssociationTypeCode/> • </fc2:PartyAccountAssociation> • Attachment A. Error Descriptions <ul style="list-style-type: none"> ○ Multiple pages <ul style="list-style-type: none"> ▪ Added the following error codes: <ul style="list-style-type: none"> • A0, B20, D44, E53, F48, G37, T27, X3, Y1-Y4, and Z1-Z15. ▪ Removed the following error codes: <ul style="list-style-type: none"> • T3 – Transmitter. Transmitter Country. State code and country code mismatch when U.S. Territory is recorded <ul style="list-style-type: none"> ○ T3 removed because it is duplicative of T8. • T19 – Transmitter. Transmitter TCC Type. The element is not recorded or does not contain a value (i.e., the value is null). <ul style="list-style-type: none"> ○ T19 removed because if this element/value is missing, it will result in a schema validation failure rather than a specific error code. ▪ Added additional clarifying Error Description text to the following Transmitter/Transmitter Contact errors: T1-T26